



Fabrication & Health Protection Guide

If video disk is missing, please visit  
<http://www.caesarstoneus.com/en/newsroom/Pages/AdsVideos.aspx>  
and select Fabrication Health Protection Video and view.

This Guide includes health and safety information and recommendations. However, it does not serve as professional advice, nor does it replace any fabricator's personal responsibility to apply all relevant health and safety measures. To protect the health and life of all employees exposed to silica dust, it is always necessary to consult with a local advisor.



# Fabrication & Health Protection Guide

Caesarstone University

# Introduction

Caesarstone USA, Inc. is the leading supplier of quartz-based slabs (“slabs”) to distributors, fabricators and installers of countertops in the United States. Fabricators fabricate countertops and other products from slabs purchased from Caesarstone USA, Inc. or its distributors. Fabricators and installers sell and install countertops manufactured from slabs to end users. Caesarstone USA, Inc. gives a Limited Residential Lifetime Warranty and a Commercial Lifetime Limited Warranty to purchasers of countertops from certified fabricators with respect to the quality of the slab used by the fabricator to manufacture the countertop sold to the end user.

This manual is published by Caesarstone USA, Inc. to inform fabricators of the recommendations of Caesarstone USA, Inc. for fabricating countertops from slabs supplied by Caesarstone USA, Inc. or its distributors to fabricators. This manual does not replace normal industry standards for the fabrication and craftsmanship – a professional knowledge of stone/quartz fabrication is required.

Any failure by a fabricator to comply with the recommended methods of fabrication of countertops from slabs may result in claims by a end user against the fabricator and refusal of a claim made by a end user under the Residential Lifetime Warranty and a Commercial Lifetime Limited Warranty given by Caesarstone USA, Inc. to the end user. Please direct any questions about the recommendations in this manual to your local Caesarstone representative’s office. Caesarstone USA, Inc. gives a Limited Residential Lifetime Warranty and a Commercial Lifetime Limited Warranty to the fabricator in respect to each slab sold by Caesarstone USA, Inc. or its distributors to the fabricator. The terms and conditions of the residential and commercial warranties to the fabricator and end user are set forth in this manual.

## Caesarstone® Fabrication & Health Protection Guide

© 2016 Caesarstone USA, Inc. All rights reserved.

No parts of this work may be reproduced in any form or by any means – graphic, electronic, or mechanical, including photocopying, recording, taping, or information storage and retrieval systems – without the written permission of Caesarstone USA, Inc.

Products that are referred to in this document may be either trademarks and/or registered trademarks of the respective owners. The publisher and the author make no claim to these trademarks.

Caesarstone USA, Inc. and/or its assigns are not responsible for errors or omissions, or for damages resulting from the use of information contained in this document. In no event shall the publisher and the author be liable for any loss of profit or any other commercial damage caused or alleged to have been caused directly or indirectly as a result of any person relying upon any information contained in this document. All work carried out by any user of this manual on any Caesarstone® slab must be done in accordance with all laws and regulations relating to that work and the slab, including but not limited to, occupational health and safety laws and laws relating to the protection of the environment.

This manual supersedes all previous manuals. Content is subject to change at any time without notice. The use of the term “Distributor” and “we” throughout this document refers to Caesarstone USA, Inc. Caesarstone® is a registered trademark of Caesarstone Sdot Yam Ltd.

---

### DOCUMENT EDITION

Version 5.2

### DATE EFFECTIVE

March 2016

### DISTRIBUTION

Fabricators, Installers,  
Distributors, Architects

# Contents

<b>Introduction</b>	<b>2</b>
<b>Fact Sheets</b>	<b>4</b>
Applications.....	4
Size.....	4
Handling.....	5
Vehicle Loads.....	5
Securing the Load.....	5
Storage.....	5
Visual Slab Inspection.....	6
Green Label.....	6
Color Match.....	6
Quartz Pattern Irregularity .....	6
Slab Sticker Identification.....	7
<b>Respirable Crystalline Silica Health Hazards &amp; Protection Guide</b>	<b>8</b>
Introduction to Guide.....	8
Hazards of Silica Dust.....	8
General Prevention Principles.....	9
Wet Tools.....	9
Filter (Exhaust) Systems.....	10
Ventilation.....	10
Dust Monitoring and Supervision.....	11
Personal Protective Equipment.....	11
Hygiene.....	12
Cleaning.....	12
Administration, Regulation and Maintenance.....	13
Installing Caesarstone Quartz Surfaces.....	13
Training Employees on Safety and Hygiene Issues.....	14
Health Surveillance.....	14
Other Information and Disclaimers.....	15
Questions and Answers.....	16
<b>Fabrication Instructions</b>	<b>18</b>
Tools and Safety Equipment.....	18
Basic Fabrication Guidelines.....	18
Inside Corners.....	19
Cutouts.....	19
Seams.....	19
Edge Detail.....	19
Polishing Edge Profiles.....	20

Mitered Edges.....	20
Motivo™ Edge Profile Fabrication Method.....	21
Polishing Texture Finish Edges.....	23
Honed and Textured Finish.....	24
Adhesives.....	25
Joint Adhesives.....	25
Laminations/Double Edges.....	25
Seaming.....	26
Joint Positions.....	26
Transportation.....	27
<b>Installation Instructions</b>	<b>28</b>
Preparing Base Units/Cabinets.....	28
Support.....	28
Overhangs.....	28
Fitting.....	28
Countertop Installation.....	29
Sinks and Basins.....	30
Table Tops.....	30
Wall Applications.....	31
Finishing Touches.....	32
Returning Slabs.....	32
Batch Tracking.....	32
Occupational Safety and Health Administration.....	32
Driver Requirements.....	32
<b>Care and Maintenance</b>	<b>33</b>
Stubborn Stains or Dried Spills.....	33
Honed, Concrete, Textured and Motivo™ Finish Cleaning and Maintenance.....	33
Heat Resistance.....	33
Tough, Yes – Indestructible, No.....	33
Special Care Considerations Form.....	34
<b>Residential Lifetime &amp; Commercial Lifetime Limited Warranties</b>	<b>35</b>
Exclusions from Warranties.....	36
Residential Lifetime Warranty.....	37
Commercial Warranty.....	39
<b>Caesarstone MSDS</b>	<b>41</b>
<b>Receipt Form</b>	

## Fact Sheets

**Applications** Caesarstone is ideal for a wide range of interior commercial and residential applications, including those subject to heavy use. Common Caesarstone applications include: kitchen countertops, bartops, vanities, interior cladding, and furniture pieces.

Caesarstone is not suitable for exterior use, or any areas that are exposed to direct sunlight UV radiation or excessive heat over 300° F.

**Size** Caesarstone is available in sizes that are ideal for kitchen counter and vanity tops. The slab sizes are:

- Standard slab dimensions are 56.5" +/- 1" (1440mm +/-25mm) x 120" +/- 1" (3,060mm +/-25mm)
- Jumbo slab dimensions are 64.5" +/- 1" (1,640mm +/-25mm) x 131.5" +/- 1" (3,340mm +/-25mm)
- Thickness options of ¾" +/- 1/16" (2cm +/-1.5mm) or 1.18" +/- 1/16" (3cm +/- 1.5mm)

These dimensions are used for storage and transportation purposes only. Actual usable slab surface is slightly less per side.

**NOTE:** Not all colors are available in all sizes and thicknesses.

**The slab dimensions are nominal only.** Actual usable slab surface is slightly less per side, and varies from slab to slab. The fabricator must inspect the perimeter for color, polish, transportation damage or any other defect that may be visible. If the slab proves to be unsuitable it should be exchanged for another prior to cutting.

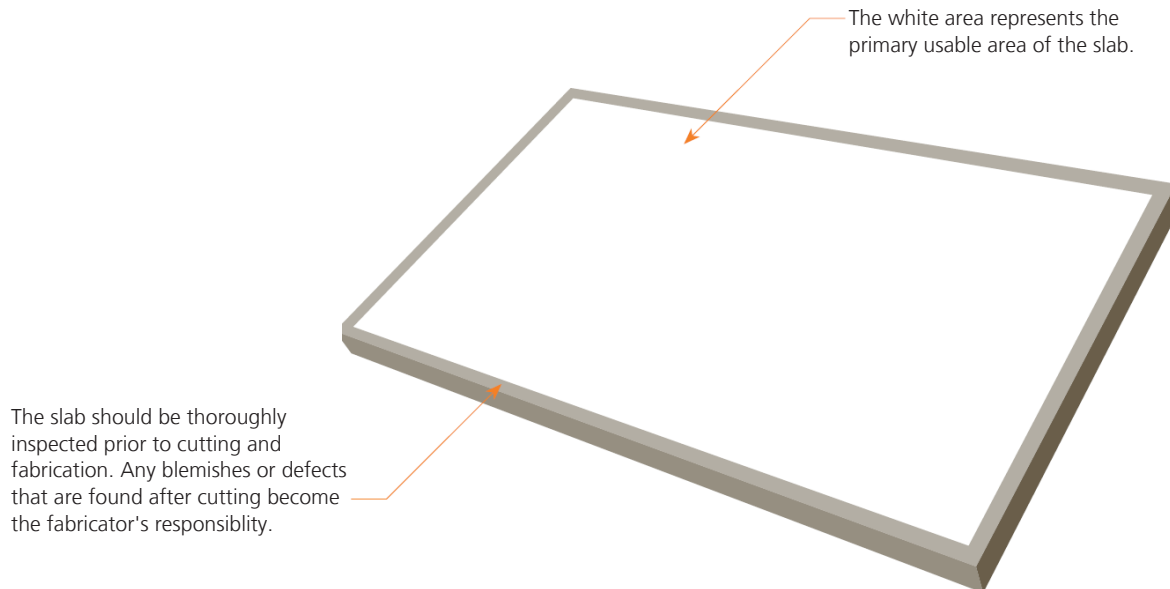





**Handling** The slabs are best loaded/unloaded from a container or truck with a forklift or lifting device capable of handling at least 2,000 lbs. (900kg).

Because of the weight, proper safety shoes and gloves should be worn.

¾" (2cm) material weighs 485 lbs (220kg). 1.18" (3cm) weighs 727.5 lbs (330kg).

Handle slabs either singularly or in multiples of two. Use clamps or sling straps and lift the slabs face-to-face. For better grip, take care to clasp the slabs from the back side (while face-to-face).

**Warning:** Keep a safe distance when handling/lifting the slabs.

**Vehicle Loads** It is the responsibility of the Driver to ensure that the load is within the legal carrying capacity of the vehicle. We have no way of determining this at our premises. As a guide you must allow approximately 485 lbs. (220kg) per 2cm slab and 727.5 lbs. (330kg) per 3cm slab, plus the weight of any other items already loaded on the vehicle.

**Securing the Load** It is the responsibility of the Driver to ensure that the load is fully supported and safely secured to the vehicle prior to leaving our premises. The Distributor will not secure the load to your vehicle.

**Storage** Slabs must be stored in a manner that prevents warping. Use at least two support beams at an angle of 15° from the vertical, measuring a height of 50" (1,300mm), and at a distance of 70" (1,800mm) apart.

Slabs should be stored so that the product is kept in a perfectly uniform manner that minimizes warping. Care must be taken to store Caesarstone slabs in a manner that allows for easy identification of color and batch numbers.

Slabs must always be stored in a way that the polished surface is not exposed to the sun. It is not necessary to store the slabs in a shaded area, but it is necessary to keep the last slabs in each rack in a position in which the backside is facing out. Storage temperatures should not exceed 129°F.

There should be no more than 20 slabs to each rack with the slabs face-to-face and back-to-back.

**NOTE:** Caesarstone is a heavy material that can cause serious injury or death if not stored or handled properly. It is recommended that all slabs be secured during storage to maintain a safe working environment including adherence to any local laws and regulations.

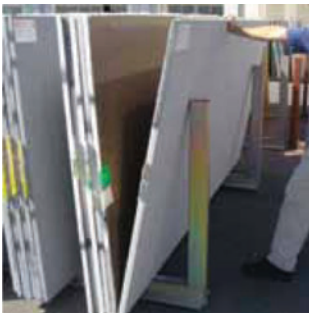
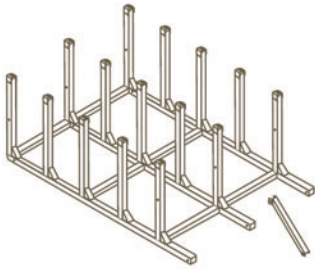

**Visual Slab Inspection** Performing a visual inspection for defects or color matching is essential when working with Caesarstone and should be a standard practice before cutting. Complete the following slab inspection steps as a guide to visual inspection for defects. **PLEASE REMOVE THE PLASTIC PROTECTIVE COVERING PRIOR TO THE VISUAL INSPECTION.**

- Hairline cracks
- Quartz pattern irregularity
- Irregular spots
- Slab-to-slab color match
- Thickness tolerance 1.5mm
- Inconsistent gloss levels
- Color consistency within the sheet
- Warpage: length 1/8" (3mm), width 1/16" (1.5mm)
- Face side pits/voids/blemishes

**NOTE:** We will not accept any claims for any of the above if the slab is modified in any way whatsoever. The Fabricator is responsible for determining if the slabs are fit for purpose. If they are not, they should be exchanged before the slabs are cut or modified in any way.

**NOTE:** Length warp should be checked using a full-length straight-edge when the slab is placed horizontally.

**Green Label** All material defined with a green label may include visual imperfections in the surface. It is your responsibility to ensure that any defect is cut around and not included in the final product. We always recommend that the end customer is shown the slab prior to fabrication.

**Color Match** An essential element of slab inspection is checking for color match. The composition of Caesarstone produces slight color variations between production cycles due to the innate and complex blending of natural minerals – a characteristic inherent in the product. Follow the strict guidelines below:

**Batch Numbering** Take all the slabs for the job from the same batch number. This should ensure a color match, however a visual inspection of the slabs is recommended to confirm consistency in color shading. Since the slabs are approximately 90% natural quartz each slab is unique and must be checked for shade and quartz distribution. The batch number is on the label affixed to all slabs. If this label is removed, the batch number can be found printed on the back of the slab.

**Picture Guide** (slab back picture)

- ① Color number    ② Batch number    ③ Slab number    ④ Production Date

**Trial Color Matching** Always do a visual color match. Before cutting, visually inspect the slabs to ensure that an acceptable color match is achieved. When doing a trial color match, the final visual inspection must be done under the same (similar) lighting conditions that will be found at the job site. We strongly recommend that you do not have slabs from different batch numbers butting up to each other.

**Quartz Pattern Irregularity** The manufacturer of Caesarstone has engineered its products to have random distribution throughout the slab. The nature of "random distribution" is such that sometimes particles will congregate in one area or will be segregated in another. If any obvious irregular distribution of particles is apparent in the slab, the fabricator must determine if the slab is suitable. If the slab is found to be unsuitable, it should be exchanged prior to cutting.

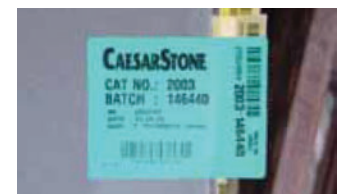
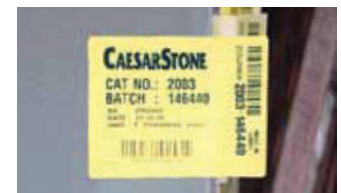



**Slab Sticker Identification** Both Yellow and Green slab sticker labels contain important information pertaining to factory production which can be useful through the transportation, distribution, fabrication, installation, and troubleshooting processes.

**NOTE: All batch numbers should be recorded for future reference.**

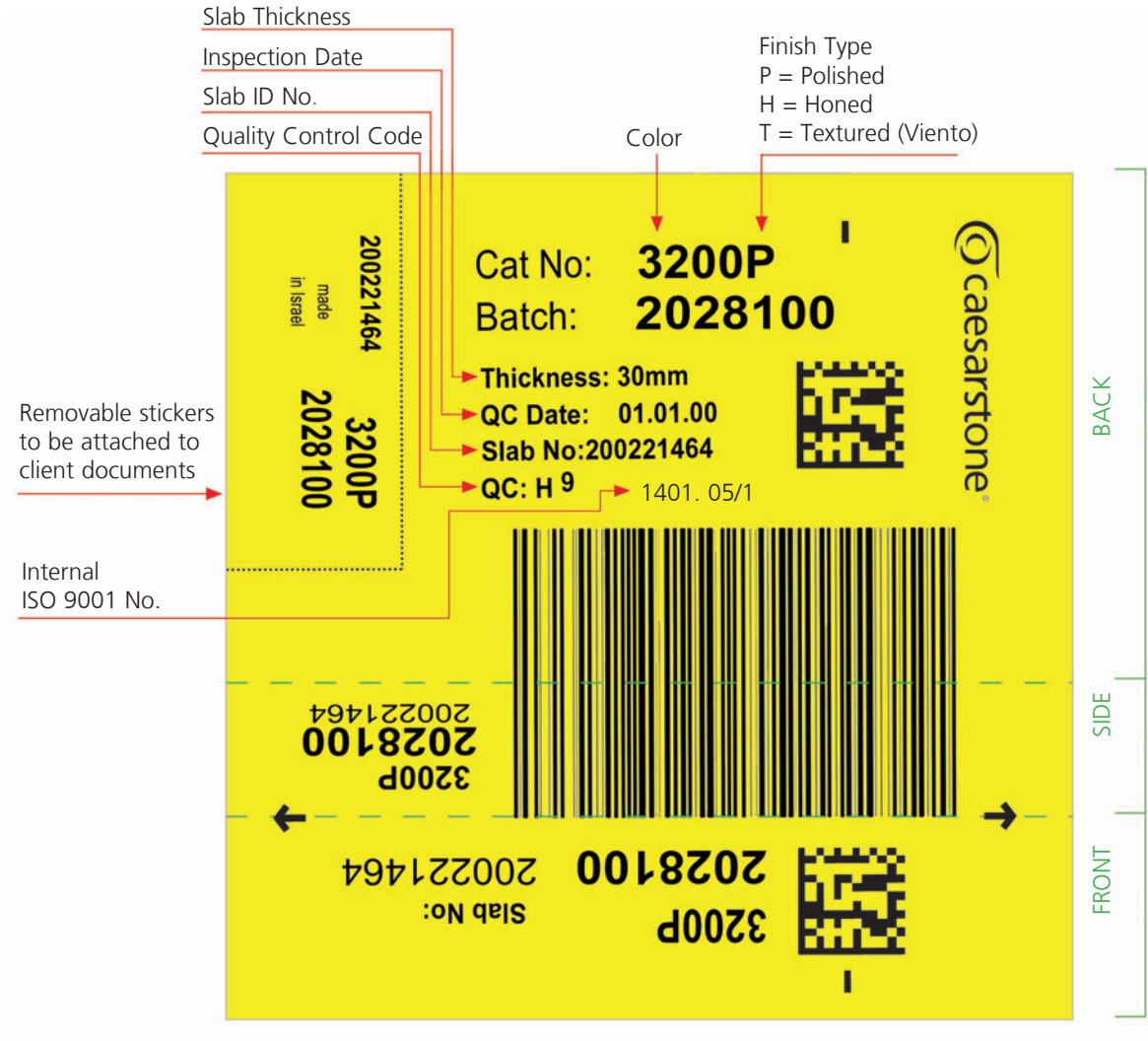

# Respirable Crystalline Silica Health Hazards & Protection Guide

## Introduction to Guide

As the world's leading global quartz surface developer and manufacturer, we at Caesarstone view the existence of a safe working environment for all employees, free of hazards and in compliance with all local laws, as a foremost interest.

Caesarstone slabs and products, as finished products, do not present any type of health risk or hazard when transported, shipped or used by the end consumer. However, their fabrication and processing generate respirable crystalline silica dust. The approximately 90% silica present in Caesarstone products (and silica present in other quartz surfaces and granite) requires fabrication and processing to be performed under particularly diligent safety conditions.

**It is important to note that the guidelines provided in this Guide are not intended to replace your local laws and regulations, which should be complied with, as further detailed below.**

Caesarstone distributors are strongly encouraged to provide their customers with the relevant information related to workplace health and safety, particularly in areas with respirable crystalline silica dust. Furthermore, the instructions in this Guide are addressed to employers and employees who fabricate Caesarstone slabs and products in order to help them control their exposure to respirable crystalline silica dust.

**The objective of this Guide is, among other things, to:**

- provide information about how the risks and health hazards caused by working in an environment with respirable crystalline silica dust are created; and
- provide certain information to assist in reducing workers' exposure to respirable crystalline silica dust, including guidance on the safe use of products containing crystalline silica in the workplace and protection that can be used.

## Hazards of Silica Dust

Caesarstone slabs and products are not hazardous when transported, shipped or used by the end consumer. However, Caesarstone slabs contain approximately 90% crystalline silica (quartz, silica sand and cristobalite), and like any natural stone product such as quartz, marble or granite, the fabrication and processing (i.e., cutting, sawing, grinding, breaking, crushing, drilling, sanding or sculpting) of Caesarstone slabs may produce dust containing fine particles of silica. This is known as respirable crystalline silica dust.

There are three dust fractions that are of main health concern: inhalable, thoracic and respirable dust. In the case of crystalline silica, it is the respirable fraction of the dust that is of concern for its health effects. The lungs take in air, extract oxygen, and release carbon dioxide. Anything that stops this process is potentially life-threatening. Silica particles may damage the lung tissue, and to protect against such particles, the body's defenses isolate them in scar tissue. Excess scar tissue, however, decreases lung capacity, which makes breathing difficult. As the scar tissue builds up through continued exposure to dust, the lungs can no longer carry out their main function – the extraction of oxygen and release of carbon dioxide.

As a result, unprotected and uncontrolled occupational exposure and inhalation of respirable crystalline silica particles without the safety measures required by law is dangerous to health and may cause severe illnesses such as silicosis, which is characterized by fibrosis of the lungs. Silicosis is a chronic and nonreversible disease, which may cause severe physical disabilities and may be fatal. The pathological process of silicosis may cause severe complications such as: lung cancer, tuberculosis and autoimmune diseases such as rheumatoid arthritis. Preexisting physical disorders may aggravate the adverse effects of exposure to silica dust.

Silicosis is an occupational disease that may affect workers in the stone fabrication industry if they process marble, granite, quartz surfaces and other natural stones without safety measures, which have been recognized for over a century. In the quartz surfaces industry, this disease can affect the production/fabrication workers themselves, and any other employee/worker who is present at the fabrication facilities (where there is silica dust) on a regular basis, for example managers and administrative staff.

PROPOSITION 65 WARNING: Quartz surfaces, including Caesarstone, contain crystalline silica, a material known to the State of California to cause cancer.

### General Prevention Principles

Silicosis and other diseases associated with silica dust as stated above can be reduced and controlled by following the required safety precautions, including those described below. Such measures include improved work practices (such as working with wet tools), engineering controls, ventilation and filter systems, respiratory protective equipment and training programmes, as further detailed below and in your local laws and regulations regarding working in environments containing harmful dust. Please note that the recommendations with respect to the work area relate mainly to the production/fabrication facilities, but also to the adjacent offices.

In order to control and reduce/eliminate the health risks associated with crystalline silica, we recommend that a Silica Control Programme be implemented in the workplace in accordance with all the applicable laws, regulations, orders and directives. This programme should be reviewed on a regular basis.

Furthermore, permissible exposure limits to respirable crystalline silica dust should be met. Exposure limits for quartz, silica sand and cristobalite (free silica – the respirable dust fraction) differ in each country, and we recommend that you consult with a local expert regarding the mandatory and recommended limits in your country.

It is important to note that the exposure and personal protection precautions are only necessary for the fabrication of Caesarstone products (cutting, sawing, polishing etc.), due to the dust that may be generated in the process, and not from the Caesarstone slab as a product.

The employer is responsible for providing his workers with all the information, tools and safety measures required in order to protect them from the dangers of exposure to silica dust. The workers are responsible for fully implementing the safety instructions. Access to the work area should be restricted to authorized employees only. By a joint effort of the employer and workers, the workplace can become a healthy environment for everyone.



#### Wet Tools

The best protection is to avoid exposure to dry silica. Therefore, where possible, implement fabrication techniques in which all cutting, grinding and shaping is performed wet.

- Operate wet tools and cutting machines as they help to prevent the release of silica dust. This applies to both manual and automated tools.
- Work with electrical systems designed by professionals to ensure safety when working with wet tools.
- Control and maintain all water systems in perfect working order according to supplier instructions.
- Take precautions to handle freezing in unusually cold weather.
- Clean and maintain all drainage systems when using water sprays and hoses.
- Wet hosing rather than compressed air should be used for clean up and in no circumstances should dust be swept up with a broom.



### Filter (Exhaust) Systems

Although the best solution is to prevent exposure to dust by using wet fabrication techniques, a second type of engineering control is to use ventilation and filtration systems specifically designed to collect respirable particles in the dust, as detailed below:

Implement filter systems that include the following elements:

- Professional extraction hoods
- Enclosure for collecting and containing pollutants
- Ducts for pollutants removal
- Filters positioned between the hood and the fan
- Fans for moving air flow and releasing clean air outside the workplace



### Ventilation

Recommendations regarding proper ventilation include the following:

- Ensure that the workplace (including the fabrication facilities, as well as the adjacent offices) have complete and effective ventilation.
- For local exhaust ventilation, dust extraction and pollution control equipment, work only with professional ventilation suppliers who employ qualified engineers for project execution.
- Position the work area as far away as possible from doors, windows and passages in order to stop wind and draft from spreading the dust and hindering local exhaust ventilation.
- Operate local exhaust ventilation at the dust source in order to capture the dust.
- Connect local exhaust ventilation to a dust extraction unit such as a bag filter/cyclone.
- Maintain local exhaust ventilation in good working order as per the supplier's instructions.
- Keep the dust source as tightly closed as possible to prevent dust dispersal.
- Ensure a constant supply of fresh air into the work area to replace extracted air.
- Release extracted air to a safe place away from doors and windows.
- Replace filters or other parts according to supplier's instructions.
- Keep air ducts as short as possible.
- Prevent employees from being exposed to local exhaust ventilation.
- Pay attention to unusual noises from fans that may indicate a malfunction.

We advise that you consult with a ventilation expert or engineer in implementing certain of the foregoing recommendations, such as work area positioning and air ducts length.



## Dust Monitoring and Supervision

Dust monitoring and supervision include the following:

- Consult your local regulations and laws as to the Permissible Exposure Limit (PEL) and/or Threshold Limit Value (TLV) limits for the legal permitted level of exposure to the different types of respirable silica dust.
- Execute risk assessment to determine whether existing dust controls are sufficient.
- Work with designated experts to create appropriate dust monitoring systems and consult with industrial hygiene professionals regarding dust sampling strategy.
- Ensure that all dust extraction emissions comply with local environmental rules.
- Keep complete records of dust monitoring campaigns and implement a quality system accordingly.
- Perform regular checks to ensure that the dust intake, filtration and expulsion systems are functioning correctly.
- Ensure that settled dust and polluted air cannot be dispersed or spread to clean areas or outside the work area.
- Select wall tiles and flooring surfaces that are hermetically sealed and easy to clean.
- Display a “Hazardous Dust” sign in all areas with hazardous dust.
- Create and enforce rules for all employees to wear protective respiratory equipment in areas with hazardous dust (as further detailed below).
- Convey to employees in charge of dust supervision the importance of setting a good example on the floor.

We advise that you consult with industrial hygiene professionals or other appropriate experts in implementing certain of the foregoing recommendations, such as creating dust monitoring systems, dust extraction and selection of wall tiles and flooring.



## Personal Protective Equipment

If dust production is not prevented by using water based machinery, workers must wear protective gear, such as P3 masks, which should be used and replaced in accordance with the manufacturer’s instructions. In cases where exposure is particularly heavy, industrial respirators should be used and comprehensive training provided.

- Personal Protective Equipment (PPE) is mandatory in workplaces where risks exist. This should be clearly marked with appropriate signage.
- PPE should comply with your local legal requirements; be designed and manufactured according to safety and health standards; and be used and replaced in accordance with the manufacturer’s instructions.
- Respiratory protection against silica dust should be P3 classification.
- As facial hair can lessen the effectiveness of a dust mask, operators with facial hair should work with air respirators or other suitable alternatives.

- Employees should receive training on the use and maintenance of the PPE, and should check efficacy of all respiratory protection equipment before use.
- Ensure that all employees wear appropriate PPE.
- Keep records of all PPE in use pursuant to applicable law.
- Provide employees who work with silica dust with overalls that prevent dust absorption.



### Hygiene

Personnel hygiene is another important factor in health protection, and includes the following:

- Provide bathroom facilities in the plant with toilets, showers, wash basins and individual lockers for storing changes of clothing. Make two checkrooms available to all plant employees: one in which they change from home clothes into clean work clothes and store their home clothes during working hours; and another in which they change out of work clothes at the end of a working day before showering and changing back into home clothes.
- Employees should wear only designated work apparel at the worksite, including footwear and socks. Employees should leave their work clothes and shoes in the workplace and never remove them from the plant.
- Launder all employees' working clothes and provide them with clean clothes each day.
- Provide explanations on the importance of separating work clothes from clean clothes.
- Employees should wash their hands and faces, and change clothes before eating.
- Permit eating, drinking and smoking only in designated areas that are not exposed to hazardous dust.



### Cleaning

- Clean the workplace, floors and all exposed surfaces on a daily basis.
- Check that the work area is clean at the end of each shift.
- Create a regular, recurring schedule for cleaning all equipment and systems.
- Employ both wet and vacuum cleaning methods.
- Provide ample vacuum connection points for a central vacuum cleaning system.
- Provide ample water connection points for wet cleaning techniques.
- Use vacuum cleaning systems for dry spillage only.



- Use only dry cleaning with brushes when wet cleaning or vacuum cleaning is not possible.
- Clean wet or dry spillage immediately; never wait for the end of day cleanup.
- Do not allow dust and debris to dry out before cleaning.
- Do not sweep with a dry broom, brush or compressed air.
- Do not clean work clothes, machines or floors with compressed air.



### **Administration, Regulation and Maintenance**

- Maintain all equipment in good working order.
- Do not make changes to any working systems without supplier approval.
- Keep instructions and diagram of installed systems in a safe place for reference.
- Ensure that regular checks are performed on inlet airflows, duct air speed and filter pressure index on ventilation systems.
- Check all systems at least once a week or according to supplier instructions.
- Keep inspection reports for a period of time that complies with local laws.



### **Installing Caesarstone Quartz Surfaces**

- In order to protect installers from working in an unprotected environment, all surfaces should be fabricated in the plant and not at the end user's location.
- If the surface needs any grinding or other dust-producing modifications at the installation site, use a wet method in an outdoors area such as a terrace or balcony. This should be performed with the appropriate P3 respiratory protection against silica dust (as detailed above), along with eye and ear protection.
- If an outdoors area is not available, dust produced during modifications should be collected with a manual vacuum with a HEPA filter and the heating/air-conditioning system should be sealed off.
- After completing an installation, thoroughly clean the work surface and remove all dust. Carry out a final check by using a dry cleaning method and clean any remaining dust and debris with a portable vacuum cleaner.
- It is important to clarify that grinding, cutting or polishing surfaces in the end user's home during installation or repair do not put the end user at any risk of disease. Silicosis and other lung diseases caused by respirable crystalline silica dust develop only as a result of long-term, regular exposure.



### **Training Employees on Safety and Hygiene Issues**

One of the keys to creating a safe work environment is providing ongoing training to employees at all levels on safety issues that are specific to their workplace. Employees who are involved in and committed to the safety programme are most likely to comply with them.

Employee training may include the following:

- Create and implement clear guidelines for safe working procedures and good practices in your workplace.
- Provide health safety and hygiene training for all new employees.
- Continue delivering mandatory training sessions to existing employees on an ongoing basis in order to update and review their knowledge of your health and safety procedures.
- Regularly review your safety and hygiene procedures. Safety issues can differ over time, and it is important to ensure that your safety programme evolves as needs change.
- Inform your employees as to how your plant deals with harmful substances such as respirable crystalline silica.
- Provide clear data about the risks associated with Caesarstone fabrication tasks.
- Provide employees with current data on health effects associated with respirable crystalline silica dust.
- Provide training for the use of respiratory protective equipment or other Personal Protective Equipment.
- Keep comprehensive records of all training provided to employees.
- Record employees' attendance at training sessions.
- Encourage employee feedback in order to improve future training sessions.
- Assess employees' knowledge after each training session in order to verify that they understand your plant's safety procedures.



### **Health Surveillance**

Health surveillance should be implemented based on your local rules and regulations, which may include the following:

- Implement a health surveillance programme for employees who are exposed to respirable crystalline silica, including medical testing and other tests as required by local regulations.
- Keep records following the termination of each employee's employment for the amount of time required by local regulations.
- If an employee is overexposed to respirable crystalline silica, he should be provided with details of his monitoring result.
- Persons under the age of 18 should not be employed in any role in which they are exposed to silica dust.
- Keep records of the protocol of all tasks that expose workers to respirable crystalline silica.

## Other Information and Disclaimers

The information contained in this Guide is, according to the best of our knowledge, current and accurate. However, it is only a summary; it is not possible in this short document to comprehensively cover all the topics mentioned, nor is it possible to cover in detail all areas of concern regarding crystalline silica dust in the workplace.

Furthermore, any recommendations or suggestions made here are general and do not take into account the specific conditions that exist at each fabrication site. In addition, **none of the content in this Guide may be construed as a recommendation for using any product or tool in violation of any laws, safety practices or other applicable terms.**

We recommend that you also consult with occupational health professionals and other experts concerning all matters regarding control of respirable crystalline silica in each specific workplace.

**We also note that the laws and regulations regarding silica dust differ from country to country, and we recommend that you check and observe your local regulations and legislation regarding working in environments containing harmful dust.**

**In any case where these guidelines contradict your local regulations, your local regulations shall take precedence.**

**None of the information contained in this Guide creates a contractual relationship between Caesarstone and any fabricator.**

Information on occupational safety and health administration appears, among other sources, at [www.osha.gov](http://www.osha.gov); the International Labor Organization at [www.ilo.org/safework/info/lang--en/WCMS\\_108566/index.htm](http://www.ilo.org/safework/info/lang--en/WCMS_108566/index.htm); the European Network for Silica at [www.nepsi.eu/good-practice-guide.aspx](http://www.nepsi.eu/good-practice-guide.aspx); [www.nepsi.eu](http://www.nepsi.eu); the "Good Practice Guide on Workers Health Protection through the Good Handling and Use of Crystalline Silica and Products Containing It," issued by NEPSI; and [www.cdc.gov/NIOSH](http://www.cdc.gov/NIOSH).



## Questions and Answers

### 1. What are silica and quartz?

Silica is one of the most common compounds on earth. Silica is composed of two elements: silicon and oxygen (silicon dioxide, SiO<sub>2</sub>).

Silica is found in nature in various forms, mainly as sand, and also as rocks and stones such as marble, granite, quartz and cristobalite. Silica is a component of many manufactured products in daily use, such as glass, pottery and quartz surfaces. Silica is very commonly used in construction and at various concentrations in bricks, blocks, tiles, slabs, cement and concrete. All human beings are extensively exposed to silica in their daily lives.

### 2. What are Caesarstone quartz surfaces?

Caesarstone quartz surfaces are an advanced solution for kitchen countertops, bathroom vanities flooring, wall cladding and other internal applications. They are manufactured from approximately 90% quartz and high-quality polymer resins and pigments.

Caesarstone quartz surfaces are in use today in millions of homes around the world, and in many environments that require the strictest standards of cleanliness and sterility, such as: Twinings Tea Development Laboratories, Assuta Hospital in Tel Aviv, the Starbucks Coffee chain in the USA and Canada, the McDonald's chain in Australia, and numerous restaurants around the world.

### 3. What is silicosis?

Silicosis is an occupational lung disease that may affect workers in the stone fabrication industry if they process marble, granite, quartz surfaces and other natural stones without safety measures. This disease has been recognized for more than a century.

Processing and polishing quartz and other substances containing silica (including other types of work such as cleaning by sandblasting) produce dust containing fine particles of silica. This is known as respirable crystalline silica. Inhalation of respirable crystalline silica over an extended period of time by workers in stone fabrication plants, without the safety measures required by law, may cause occupational lung disease, including silicosis, which is characterized by fibrosis of the lungs. Silicosis is a chronic and non-reversible disease, which may cause severe physical disabilities and may be fatal. The pathological process of silicosis may cause severe complications such as: lung cancer, tuberculosis and autoimmune diseases such as rheumatoid arthritis.

In the quartz surfaces industry, production workers are at risk of developing these diseases, as well as any other employee/worker who is present at the fabrication facilities (where there is silica dust that can originate from quartz or cristobalite, for example) on a regular basis, such as managers and administration staff.

### 4. Can silica dust hazards be prevented?

Yes. Exposure to silica dust and the diseases that may result from such exposure (including silicosis) can be reduced and controlled if the proper safety measures are implemented. These measures include working with water-injected tools, using dust masks or respirators and installing ventilation and filter systems in the workplace to reduce or eliminate the concentration of silica dust in the air.

For further information, see the Caesarstone *Respirable Crystalline Silica – Health Hazards & Protection Guide* and information on occupational safety and health administration, among other sources, at [www.osha.gov](http://www.osha.gov); the International Labor Organization at [www.ilo.org/safework/info/lang--en/WCMS\\_108566/index.htm](http://www.ilo.org/safework/info/lang--en/WCMS_108566/index.htm); the European Network for Silica at [www.nepsi.eu/good-practice-guide.aspx](http://www.nepsi.eu/good-practice-guide.aspx); [www.nepsi.eu](http://www.nepsi.eu); in the "Good Practice Guide on Workers Health Protection through the Good Handling and Use of Crystalline Silica and Products Containing It," issued by NEPSI; and [www.cdc.gov/NIOSH](http://www.cdc.gov/NIOSH).

Always apply your local laws and regulations regarding working in environments containing harmful dust.

## **5. Who is responsible for ensuring the health and safety of stone fabrication workers?**

The owners of stone fabrication plants and the employers are responsible for their own health and the health of their workers, in all matters related to work in these plants. Stone fabrication plants that operate according to the legally required safety regulations for working with harmful dust ensure the health and safety of their workers.

The employer is responsible for providing his workers with all the information, tools and safety measures required in order to protect them from the dangers of exposure to silica dust and for enforcing their implementation. The workers are responsible for fully implementing the safety instructions. By a joint effort of the employer and his workers, the workplace can become a healthy environment for everyone.

## **6. Can Caesarstone surfaces installed in the home be harmful to the consumer?**

Absolutely not. Silica is non-toxic and Caesarstone quartz surfaces are completely safe for domestic use.

The health risk lies in the processing procedure, if performed not in accordance with legal requirements, and not in the surfaces themselves.

A small amount of silica dust is sometimes produced during installation or repair of Caesarstone quartz surfaces in the end user's home. This poses no health threat whatsoever to the end user as silicosis and other diseases caused by silica dust develop only as a result of ongoing occupational exposure to silica dust. Silicosis is purely an occupational disease.

## **7. Does Caesarstone meet industry standards for health and environment?**

Caesarstone quartz surfaces maintain the most stringent industry standards for health and environment, as listed below, and presented on the Caesarstone web site.

- Caesarstone products are compliant with the National Sanitation Foundation International standard, ensuring that our working surfaces are safe for use in all food environments.
- Caesarstone quartz surfaces comply with ISO 14001, ISO 9001 and OHSAS 18001.
- Caesarstone is a registered member of the United States Green Building Council (USGBC).
- Caesarstone surfaces comply with the American GEI (GREENGUARD Environmental Institute) certification, which primarily verifies that Caesarstone's products meet the most stringent air emission standards.
- Caesarstone's recycled range of quartz slabs incorporate 15-40% first quality reclaimed quartz from the fabrication process (postproduction recycled) and post-consumer recycled glass and mirrors.
- Caesarstone surfaces are kosher due to their low porosity.

# Fabrication Instructions

## Tools and Safety Equipment

It is critically important that all fabricators wishing to fabricate Caesarstone have the proper tools and safety equipment to produce a quality finished product safely and efficiently. Below is a list of tools and safety equipment that are either essential or recommended to meet this objective.

### Basic Tools

- Bridge saw
- Electric/pneumatic polisher (variable speed preferred)
- Diamond grinding wheel
- Diamond polishing pad
- Grinding stone
- Core bits
- Diamond contour blade
- Wet profiling machine (edge router)
- Stone carts/dollies
- A-Frame/storage racks
- Fabrication stands
- Air compressor
- Pneumatic seam setters with leveling points
- Water source

### Basic Fabrication Guidelines

The following guidelines should be followed to ensure a high quality product:

- Do not change the original surface finish of the slabs by re-polishing, honing, sealing, or otherwise altering the factory finish.
- To avoid overheating the slab, only water-cooled tools should be used for cutting, drilling, and polishing Caesarstone®.
- Do not cut square corners (cross cut) as this will create stress points in the slab and may result in cracking.
- When cutting an inside corner, always use a core bit to avoid damaging the corner area with the cutting disc. Damage to the radius area will create a stress point.
- Any internal angled corner must be radiused. Cut with the saw up to the joint of the drilled hole, leaving the drilled hole intact. Avoid dry grinding/polishing of the corner since overheating the area may result in a crack.

### Advanced Tools

- Water jet
- CNC
- Automated profiler
- Diamond jig saw

### Basic Safety Equipment

- First-Aid kit
- Safety glasses
- Dust masks
- Safety gloves
- Steel-capped safety shoes
- Aprons
- Ear plugs



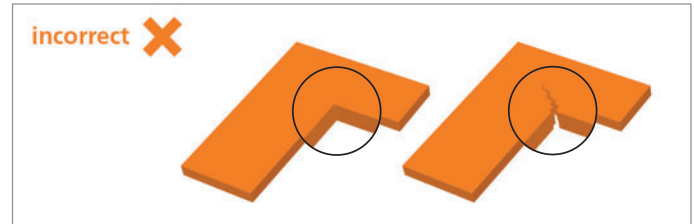
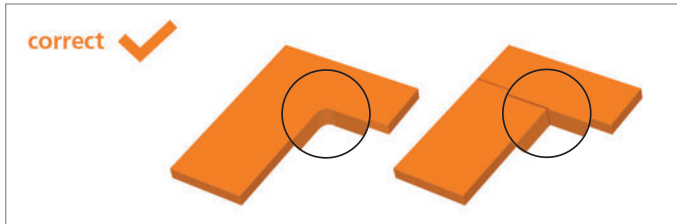

**Inside Corners** In the case of an angular shaped kitchen (L- or U-shaped), the surfaces of the countertop should be fabricated from a single slab. Inside corners must have a minimum  $\frac{3}{8}$ " radius; the larger the radius the stronger the corner.

### Cutouts

- If the distance between the cutout and a joint is less than 6", the area needs to be supported. This can be achieved by ensuring that all joints are placed at the junction of the base cabinets or a solid slat be fitted under the joint.
- Cross cutting should be avoided. When preparing a cutout always use a core bit. Avoid damaging the drill area with a cutting disk.
- Damage to the drilled area can result in stress points that may lead to hairline cracks. All cuts should be done using only wet diamond cutting tools to avoid generating excessive heat, which could also result in hairline cracks.
- Always allow an extra  $\frac{1}{8}$ " between the appliance and the edge of the cutout for expansion.

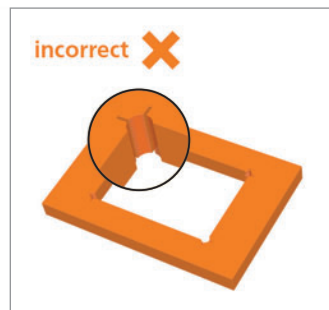
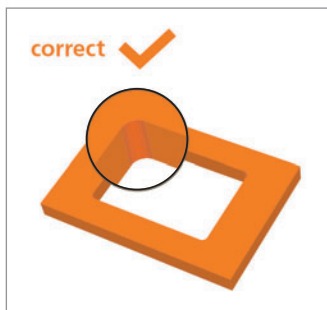

**NOTE:** Chiseled or hammered edges are not approved edge details.

\*Do not use square edges.

### Seams

- Straight seams are always recommended.
- All seams should be made level by adjusting the material before adhesive sets.
- Do not surface polish seams to make them even/level.
- Use pneumatic seam setters with leveling points to make seams as narrow and inconspicuous as possible. Seams should not be more than  $\frac{1}{16}$ " wide.

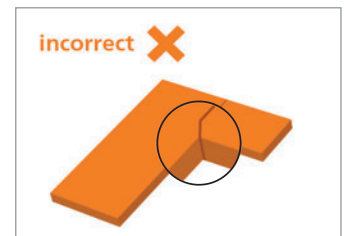
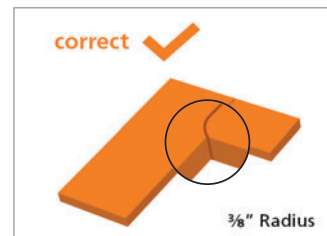

### Edge Detail

- All exposed edges must be fabricated to the same finish as the surface.
- All edges must have a minimum edge profile of 3-4 mm ( $\frac{1}{8}$ ").
- The top and bottom of edges must be rounded or beveled.
- Our preferred edge detail is a Pencil Round edge.
- The larger the surface area of the edge, the more resistant it is to chipping.
- For high use areas, such as sinks or commercial applications, Caesarstone recommends that the edge details have a minimum of 6 mm ( $\frac{1}{4}$ " ) radius on both top and bottom, and a minimum of 6 mm ( $\frac{1}{4}$ " ) on outside corners.

**Polishing Edge Profiles** Polishing any Caesarstone edge profile should be done in a progressive manner using only granite or marble diamond polishing pads. Caesarstone recommends the use of premium quality pads and use of plenty of water for best polishing results. The quality of the pads being used will affect the time required to complete polishing and the quality of the finish. Polishing Caesarstone should be done by starting with a surface that is smooth, clean, and free from any residual adhesive.

**NOTE:** Care must be taken not to overpolish edges in excess of the factory surface polish.

The type of tools, diamond pads, and fabrication techniques will affect actual polishing results. When polishing the edge profile, use water-cooled tools. Dry-polishing the edge profile or cutting/polishing too quickly, even with water, may cause burning of the resin, leaving the edge prone to chipping. Excessive heat undermines the physical structure of the slab, and although not visible to the naked eye, micro-fissures are formed, leading to chipping upon impact, discoloration and an uneven polish.

- Use lower RPM on polishers, typically half the speed used on natural stone.
- Do not use stone “buff” pads on Caesarstone.
- Do not overpolish edge details in excess of the factory surface polish.

### Mitered Edges

- Mitered edges should be done at a 45° angle to ensure maximum strength. The joint should be clean, flush, and parallel.
- Mitered edges have the greatest area of weakness and are most prone to chipping. Our preferred minimum edge profile is a 1/8” (3–4mm) radius edge.)
- Chipping is most prevalent where the application of the adhesive is not evenly distributed throughout the joint.

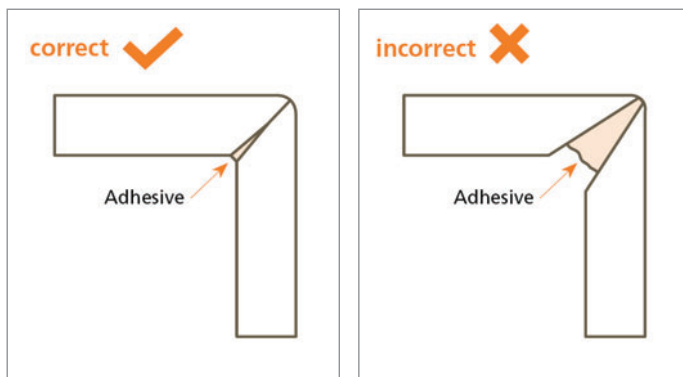

- Do not cut edges at less than 45° as this makes the edge prone to physical damage such as chipping.
- Incorrect angles restrict the type of edge that can be produced, since the larger the edge profile, the larger the joint that is visible.

**NOTE:** Internally score the material at the joint location and ensure that the adhesive is thoroughly distributed throughout the joint for maximum strength.

## Motivo™ Edge Profile Fabrication Method

There are three methods of fabrication edge profiles with Motivo™, as described on these pages.

### A. Fabricating Miter Edge Profiles

Fabricate 45° miter edge profiles using Motivo™ for both surface and the edge in order to create visual continuity of the pattern.

1. Plan the cutting of the slab so that the cut piece can be attached to the surface at a 90° angle and maintain visual continuity of the pattern.
2. Cut the slab at the appropriate location.
3. Fabricate a 45° miter edge profile from the two cut pieces.
4. Glue the miter edges together to create 90° angle with a 45° miter edge.
5. Shape the miter edges with a 3mm (1/8") radius.

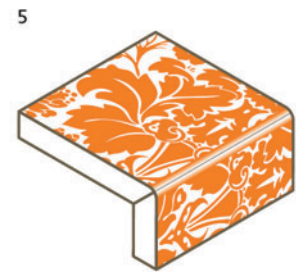
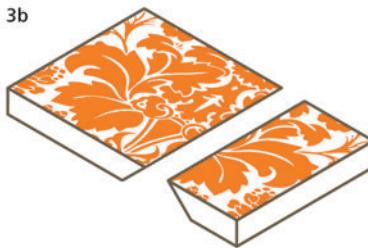
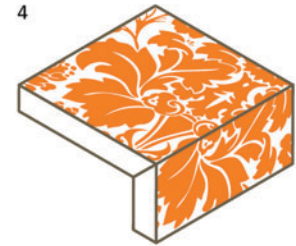

Motivo™ Finish



Textured Finish



Polished Finish

## B. Fabricating Miter Edge Profiles with Combined Surface Finishes

Miter edge profiles can also be fabricated using a combination of Motivo™ and either polished or Textured Surfaces, in order to create a new, fresh-looking concept.

### Combined Motivo™ and Polished Miter Edge Profiles

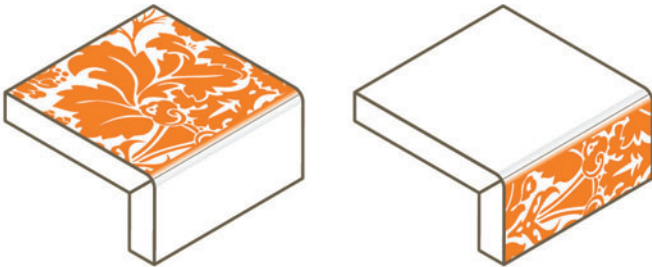

### Combined Motivo™ and Textured Miter Edge Profiles

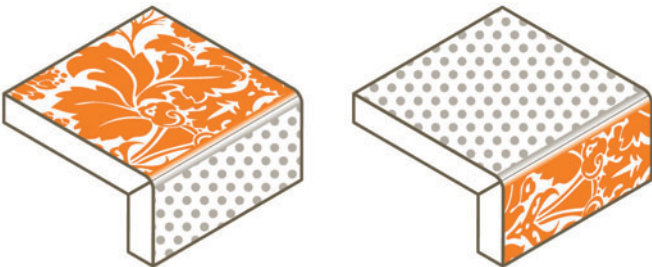

Motivo™ Finish



Textured Finish



Polished Finish

## C. Fabricating Regular Edge Profiles

An additional method of fabricating Motivo™ edge profiles is by polishing the natural edge of the full thickness of the slab with polishing pads and/or brushes to create either a Polished or a Textured Finish.

### Polished Edge Profile



### Textured Edge Profile



**NOTE:** The Polished edge profiles is the preferred method of regular edge profile fabrication, as the polished area of the surface is greater than the Textured area.



### Miter Clamp

It is recommended to use a miter clamp to tighten the join in order to prevent the adhesive showing and create an accurate 90° angle, e.g., the Mitreforma™ clamp; [www.mitreforma.com.au](http://www.mitreforma.com.au).

### Polishing Texture Finish Edges

The natural, unique look of **texture** finish combines a low level of gloss, making it beautiful to both see and touch. Due to the innovative technology used to create lightly textured surfaces, we recommend the following guidelines below to ensure the highest quality workmanship and an optimal result when polishing texture finish edges.

We are recommending that a mitered edge be used for this material, as it will achieve the best textured appearance. However if any other edge is demanded, special fabrication and brushes will be required for the edge detail.

1. Complete cutting the surface into the required pieces/sections, before proceeding with polishing.
2. Using clamps, attach all pieces required for the final design to a suitable work surface.
3. In cases where the texture finish edge will require gluing, it is recommended to do so prior to polishing.
4. Cut or shape the required edge profile.
5. Smooth and polish the edge shape, following standard polishing procedures and according to regular levels – up to a maximum of 100–120 grain.
6. Polishing of texture finish surfaces must be executed while wet, using a generous amount of water.
7. Polishing a texture finish edge will require approximately the same amount of time as polishing a regular edge.
8. Use a suitable manual, electric or pneumatic angle grinder – with a low RPM of 600–1200; connect it to a source of water and attach a 60 grain **special texture brush**.
9. Begin polishing the texture finish using movements similar to those used when polishing a regular edge.
10. Continue until the edge attains a homogeneous, textured finish.
11. Change the brush to a 120 grain and polish until there are no visible signs remaining of the 60 grain brush.
12. Repeat the above with 400, 800 and 1600 grain brushes or until the edge is consistent with surface texture.

**NOTE:** Only Certified Fabricators with Texture training can purchase this material.

### Honed, Textured, Motivo™ and Concrete Finish

**Cleaning** Please understand that **Honed, Textured, Motivo™ and Concrete** finishes will require more daily cleaning than our polished finishes. Since there is more exposed surface area with these finishes, metal marks, fingerprints and other signs of daily living will show on these materials. Most of these marks can be removed with a little effort and cleaning products such as Soft Scrub® Liquid Gel with Bleach or Barkeeper's Friend. Rinse thoroughly with water.

Honed, Textured, Motivo™ and Concrete materials may receive slight surface markings during transportation, fabrication, or installation. These marks can usually be removed using the cleaning methods mentioned above.

**NOTE:** Under no circumstances should any type of stone-impregnating sealers be applied to any Caesarstone surface.

When fabricating any Caesarstone material with a honed/concrete finish, take care not to overpolish any edge details beyond the finish on the slab face surface.

All Caesarstone fabrication requires fabricators to avoid modifying the factory polish on the face of the slabs.

**NOTE:** A *Special Care Considerations Form* should be signed by the homeowner prior to purchase, accepting the additional cleaning needs.



**Adhesives** It is important that a flexible adhesive be used, such as 100% clear silicone adhesive be used to secure the countertops to the cabinets, substrate, or to secure Caesarstone backsplashes to the wall. This will allow for limited thermal expansion.

The use of non-flexible adhesives, such as epoxies, liquid nails, or construction adhesive, is not recommended. Caesarstone will not warrant any claims for cracks that are the result of tops being bonded to the base cabinets with non-flexible adhesives.

Follow stone adhesive manufacturer's instructions. Observe good stone working and safety practices at all times and comply with applicable building codes and regulations.

**Seaming & Laminations** Caesarstone requires that all fabricators follow the individual manufacturer's instructions for the use of their seaming adhesives, including but not limited to the minimum working temperatures for their product. Failure to follow the prescribed instructions will void the Caesarstone warranty.

**Joint Adhesives** In order to achieve a minimally visible seam, the adhesive used must be pigmented to a color similar to that of the material being installed. This can be done using color paste pigments hand-mixed with the adhesive to achieve a color match. Caesarstone recommends the use of a polyester resin knife grade adhesive for all seaming and laminations.

**Laminations/Double Edges** When laminating, it is important to make sure that the lamination piece is the full length of the top piece and cut at 45° on the corners. If this cannot be done and a joining of the lamination pieces is unavoidable, the joint must be cut at 45°. The use of a mitered end cut reduces stress on the material that may cause stress fractures.

The lamination strip should be cut from the same slab as the counter top surface material to ensure a color match. It's recommended when cutting the piece to be laminated, to add the lamination piece size to your cutting measurements, ensuring that you will have the same length and same color piece for your lamination.

- A 45° corner joint is recommended to minimize the stress on corners.
- Use full-length lamination pieces.
- For very long countertops where a joint is required, ensure that the joint in the lamination piece is at 45° to reduce any stress points.

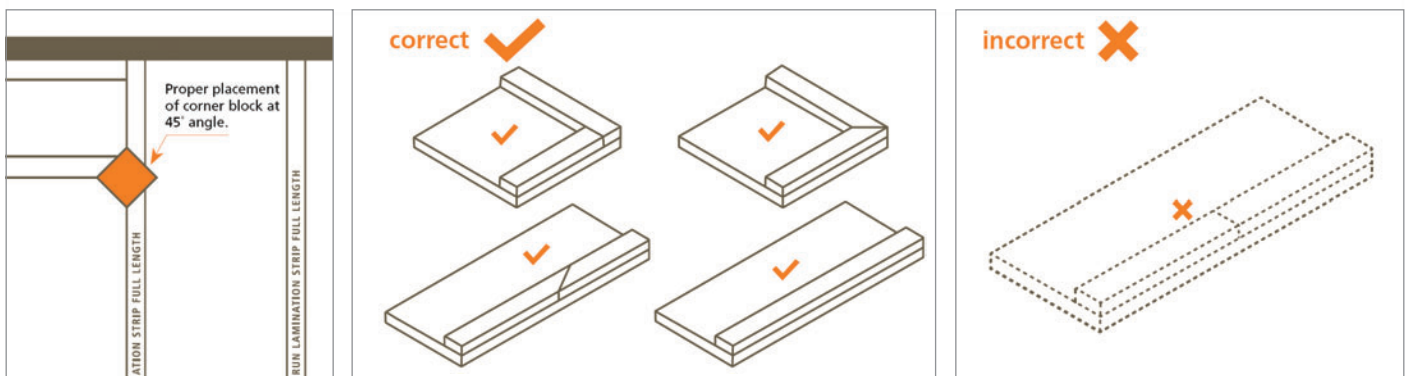

## Seaming

- Use a pneumatic seam setter with leveling pins to make seams as narrow and inconspicuous as possible. Note Picture A. Seams should not be more than 1/16" wide. **Support must be provided under all countertop seams.**
- All seam surfaces should be smooth, clean and free of debris.
- Caesarstone requires the use of colored glue for all seams. This can be accomplished by using one of the premixed Integra colors available or by manually tinting the glue of your choice.
- Grooves should be created in surfaces to be joined to allow space for glue. Extra glue should be placed at all corners and around joints. Note in Picture C1 and C2.
- Seam locations should be carefully planned to minimize visibility.
- Caesarstone prohibits the surface polishing of seams.
- Never install mechanical fasteners (screws, nails, etc.) into Caesarstone.

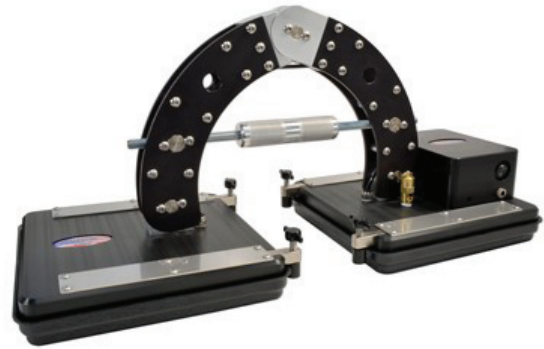

Picture A

This is an example of a pneumatic seam setter available at Braxton Bragg.



Picture B

## Joint Positions

- A seam over a dishwasher or any appliance is not permitted.
- On seams, miters, and lamination areas, it is necessary to grind notches or grooves on the surfaces to be bonded together.
- Caesarstone is nonporous and will not absorb the adhesive – these notches provide a space for the adhesive within the joint.



Picture C1



Picture C2

## Transportation

### Packing for Transport

- Countertop sections are normally heavy and fragile. Consideration must be given to portability and site access when planning and packing for transport.
- Brace all cutouts to avoid flexing of the seams and corners.
- Transport Caesarstone with sections touching face-to-face or back-to-back. A protective barrier, such as corrugated plastic sheets, should be placed between the pieces to avoid surface abrasion on the product. Do not allow any parts to slide around during transportation. Make sure the face is always protected and not touching metal, the back of another slab, etc.

### Racking for Transport

- Time and skill has been spent in the factory manufacturing a first-class product. Good racking is essential for getting the product to the site in good condition.
- Many rack designs have been made for stone slab transportation devices. Some prefer to have a removable "A" frame that they can hoist off the delivery vehicle.
- The slabs should be securely fastened to the rack by straps. Care should be taken to protect the straps from being damaged or cut by the edge of the slabs.
- At least two people should be taken on the delivery vehicle to get the product onto the site.
- All racking should have a protective layer between the rack and Caesarstone material. This will help to prevent scratching or other surface damage during storage or transit.



# Installation Instructions

**Preparing Base Units/Cabinets** Ensure that cabinets are complete and satisfactorily installed. Verify that all cabinets are level. The tops of the cabinets must be flat and true within  $\frac{1}{16}$ " (1.5mm) over 18" (457mm). The cabinets should be affixed to each other and then secured to the back wall. In the case of a dishwasher, make sure that the surrounds of the opening of the counter will have sufficient support. The front edge of any countertop over a dishwasher should always be supported with material matching the installed cabinets to better match the kitchen.

**NOTE:** If cabinets do not meet the minimum standards, the installer must notify the homeowner or project manager present at the jobsite prior to installation of tops.

**Support** Below are some guidelines on installation, material, and type of supports:

- Caesarstone must be supported on a strong perimeter frame.
- Front-to-back support within the cabinet should be provided every 24". Plan for front-to-back support strips 2.5"-wide (40mm–100mm) to coincide with cutouts and periodic support. **Support must be provided under all countertop seams.**

**NOTE:** Support is required across the top of a dishwasher space and over any other appliance.

- **Overhangs** As a general guideline, support is required for overhangs of Caesarstone. The following guidelines are for standard cabinets 24" in depth but in no case may the overhang be more than  $\frac{1}{3}$  of the width of the countertop. Cantilevered countertops exceeding these dimensions will require corbelled supports beneath the stone.

2CM ( $\frac{3}{4}$ " )	2CM ( $\frac{3}{4}$ " ) with $\frac{5}{8}$ " substrate	3CM (1.18")	MATERIAL SUPPORT REQUIRED
Less than 8" (200mm)	Less than 12" (300mm)	Less than 16" (400mm)	No additional support required.
8–16" (200–400mm)	12–20" (300–500mm)	16–24" (400–600mm)	Brackets required at 24" (600mm) intervals.
Over 16" (400mm)	Over 20" (500mm)	Over 24" (600mm)	Legs, Columns or Panels required at 24" (600mm) intervals.

## Fitting

- Space should always be allowed as Caesarstone needs room to expand. Each countertop requires at least  $\frac{1}{8}$ " at each wall for expansion and contraction.
- When affixing the Caesarstone surface to the supports, use only dabs of flexible silicone 8–12" apart. Extra adhesive must be placed along all joints and cutouts.
- Mechanical fasteners (screws, nails, etc.) must never be affixed directly onto Caesarstone. Through bolting is permitted as long as the hole is larger than  $\frac{3}{4}$ " and allows for  $\frac{1}{8}$ " expansion room around the bolt.

**Countertop Installation** We only recommend the use of 100% silicone adhesive for affixing Caesarstone® surfaces to cabinets and for all supports.

### Legend

- 100% silicone dabs.
- - Top of edge detail
- R Radius

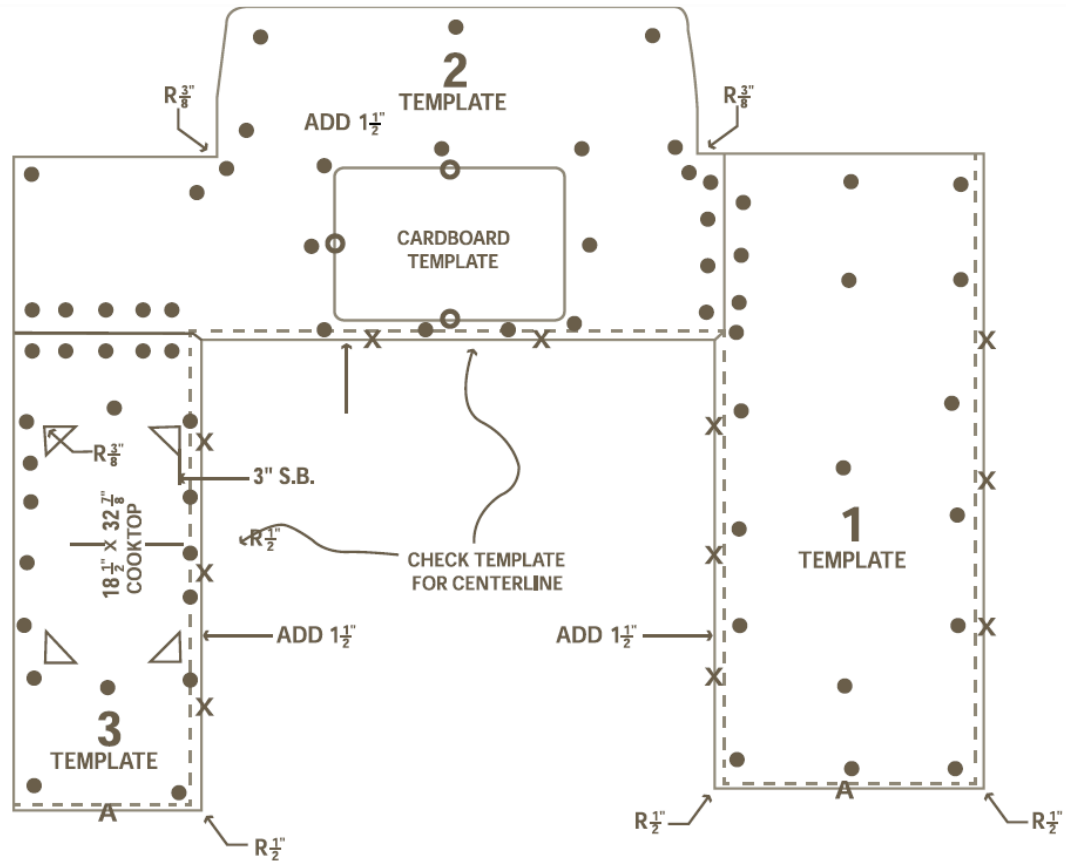

### Securing of Countertops

- Fix top using dabs of silicone 8–12" apart.
- Use extra silicone on all corners, joints and around all cutouts
- Support is required on overhangs over 8" (200mm) for 3/4" (2cm) thick slabs and 16" (400mm) on 1.18" (3cm) slabs.
- Radius all inside corners on all cutouts "to a minimum of 3/8".
- Use color matched adhesives to join the seams.
- Do not undercut corners.
- Allow 1/8" clearance room for expansion between tops and walls.
- All cabinets must be leveled and supported prior to the installation of the tops.
- If the cabinets are on adjustable legs, please ensure that all legs are evenly tensioned to prevent any movement.

## Sinks and Basins

- Regarding cutouts, follow the recommendations on Page 19 of this manual. For under-mount installations, we recommend the use of a 1/4" radius on the edge detail to reduce the risk of chipping.
- Twin basin installations (Top- or Under-mount), where the tap hole is in the countertop, require extra care to ensure that there is sufficient material left for strength. Extra support is required to ensure that no cracking occurs.
- All sink cutouts must be made using drilled radius corners (minimum 3/8") to prevent stress points in the top.

We recommend that all sink installations be fully supported independent of the Caesarstone top. Please be sure to use a professional sink-setter or support rail system. Plan for front-to-back support strips 2.5"-wide (40mm–100mm) to coincide with cutouts and periodic support. **Support must be provided under all countertop seams.**

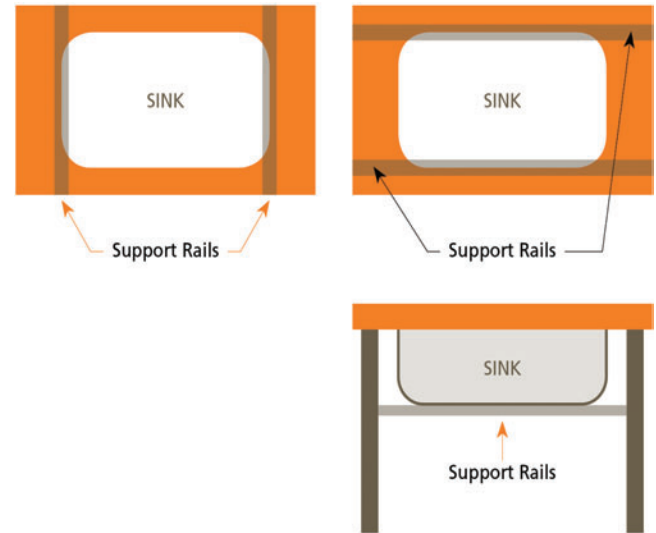

**NOTE:** Under no conditions can mechanical fasteners (screws, nails, etc.) be affixed directly to Caesarstone.

### Under-mount sink installations

- All under-mount sink cutouts must have the inside edges polished to match the surface.
- All under-mount sinks should be sealed to the countertop using 100% silicone.

**Table Tops** If you are using Caesarstone as a freestanding tabletop, care needs to be taken with the method by which the top is secured to the base. This is of the utmost importance when the table has only one central leg as support. A silicone adhesive may be too flexible to adequately secure the Caesarstone top to the base.

In this situation we would recommend a stronger, more rigid adhesive be used (such as a construction adhesive like polyurethane [Sikaflex®-11 FC] which is strong yet still flexible) to ensure that the top is properly secured to the base.

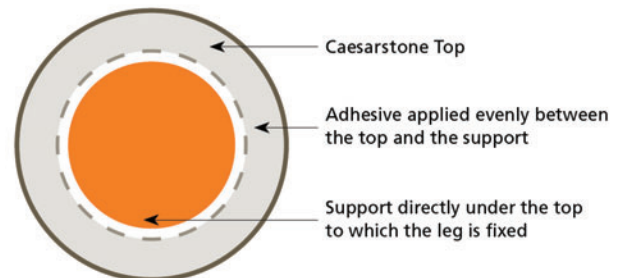



**Wall Applications** Structural requirements for Caesarstone require that wall surfaces to be covered be sound, secure, rigid and conform to all applicable laws and engineering practices. Maximum allowable deflection is L/360 and should be uniform over the length of the span. All surfaces must be true and level within 1/8" over ten feet.

Caesarstone recommends only the use of latex thin-set mortar adhesive or epoxy adhesive and grout for all wall applications.

All bedding and grouting mortars should be weather, frost, shock, and chemical-resistant, and meet the following physical requirements:

Compressive Strength:	Thick-bed mortar	3000 PSI Minimum
Compressive Strength:	Thin-bed, bonding, grouting mortars	500 PSI Minimum
Tensile Strength:	Thin-bed, bonding, grouting mortars	500 PSI Minimum
Water Absorption		4%
Ozone Resistance:	200 hrs @ 200ppm	No loss of strength
Smoke Contribution Factor		0
Flame Contribution Factor		0

- The finished mortar and grout should be resistant to urine, diluted acid, diluted alkali, sugar, brine and food waste products.
- Caesarstone can be applied over concrete, block and masonry-type surfaces, gypsum wallboard, plasters, cement backer board, plywood, asphalt, and steel with proper preparation and the use of appropriate adhesives and grout.
- Caesarstone and its setting and grouting mortars do not constitute a waterproof barrier and should not be considered a replacement for a waterproof membrane. For information on thin, load-bearing waterproof membranes, consult your preferred supplier.
- Caesarstone surfaces to be bonded must be free of dust, oil, grease, paint, tar, wax, curing agents, primers, sealers, form release agents, or any other deleterious substances which may act as bond barriers.
- The installer is responsible for ensuring the removal of any such contaminant prior to the commencement of Caesarstone installation.
- All mortar additives, epoxy adhesives, and grouts should be from one manufacturer to ensure compatibility.
- All Caesarstone should be handled in a manner to avoid chipping, breakage or the intrusion of foreign matter.
- Handle, store, mix and apply all setting and grouting materials in strict compliance with the manufacturers directions.
- Observe good stone working and safety practices at all times and comply with applicable building codes and regulations.

**Finishing Touches** If further construction work is to be performed at the job site after the installation of the surface is complete, ensure that the Caesarstone surface is properly protected by covering the entire top with corrugated plastic sheeting or another protective material.

Please make your customer aware that any successive trades must not use the new countertop as a workbench, a stepping or a standing platform, and that any trades using solvents or adhesives should take due care to avoid and/or remove any spills created by their solvents or adhesives.

**We strongly recommend that your customer confirm, in writing, their satisfaction with the material and workmanship at the end of the job to cover you against damages caused by others.**

**Returning Slabs** Any slab that is not suitable should be returned for credit or exchange. This can only be done providing the slab has not been altered in any way. If exchanged within seven days, no restocking fee is applied. After seven days a restocking fee may apply. After 30 days, no return is accepted.

**Batch Tracking** Although we do our best to record all batches that are sold, it is your responsibility to maintain a record of the batch number as listed on the back of the slab. We cannot guarantee that we will always be able to supply you this information on invoices in the future.

**OSHA** The Distributor has an OSHA Policy in place to ensure the safety of all persons on our premises. All visitors must observe any direction given by our staff and also follow any warning signs that are posted throughout the warehouse.

### **Driver Requirements**

- Drivers should stay with their vehicles and ensure the slabs being loaded are suitable.
- Drivers are not to wander through the warehouse unless accompanied by an authorized person.
- Contract Drivers should be made aware of which orders are to be collected. This is especially important when there are several orders pending pickup or delivery. The Distributor will not be responsible for extra charges for goods missed on the initial delivery.

## Countertop Care

**Regular Cleaning** Due to Caesarstone's high density and non-porous qualities, normal cleaning with a damp cloth and mild detergent is all you need to keep your Caesarstone surface looking great. Thoroughly rinse off the soap/mild detergent with hot water after use and dry with soft cloth or paper towel. To avoid dulling the surface shine, make sure to use a non-abrasive cleaner, and thoroughly rinse off with water after use. Those wishing to use environmentally safe cleaners may also use a combination of 50/50 vinegar & water, rinsing afterwards.

**Stubborn Food Stains** If needed, apply a generous amount of a **non-abrasive gel**, such as Soft Scrub Liquid Gel with Bleach, to a damp soft cloth or paper towel (not directly on to the countertop). Wipe the area using a circular motion, rinsing thoroughly with water and dry with soft cloth or paper towel. We recommend a thorough cleaning of your Caesarstone surface on a regular basis (because of the patina that will develop on the surface from day-to day use) to keep the surface as beautiful as the day it was installed.

**Metal Marks/Rust Special Use for spot cleaning ONLY** – Because of the abrasive nature of this cleaner, use Liquid Barkeeper's Friend only as follows: Place small amount on damp cloth. Using very light pressure, wipe the area where the marks are in a circular motion, rinsing thoroughly with warm water and dry with soft cloth or paper towel.

**Dried Spills** To remove adhered material such as food, gum or nail polish, first carefully scrape away the excess material with a plastic putty knife and then clean the surface with a damp cloth to remove any marks left behind and any residual dirt. Also, **do not use any abrasive pads** to clean tougher dirt as abrasives can damage the finish/sheen of your countertops.

Please note that HONED, CONCRETE, MOTIVO and TEXTURED finishes require more cleaning than our polished finishes. Since there is more exposed surface area with these finishes, metal marks, finger prints and other signs of daily living will show on these finishes. Most of these marks can be easily removed with little effort and **non-abrasive** cleaning products such as Soft Scrub Liquid Gel.

**Are there any chemicals or cleaners to avoid using?** Prolonged exposure to cleaning solutions may cause permanent damage/discoloration to the countertop surface. Avoid exposing Caesarstone to chemicals, such as oven grill cleaners, floor strippers, paint removers/strippers, toilet bowl cleaners, oil soaps, tarnish removers, furniture cleaners, drain products, battery acid, dishwasher detergent, etc. Should your surface accidentally be exposed to any potentially damaging products, rinse immediately with water to neutralize the effect.

**How does Caesarstone withstand heat?** Caesarstone is structurally more heat resistant in comparison to other stones, including granite. However, any stone material can potentially be damaged by sudden and rapid temperature changes, especially near the edges. Therefore, using inexpensive and readily available trivets is always recommended, especially when using cooking units such as electric frying pans, crock pots, or toaster ovens. **Do not put hot cookware directly on the Caesarstone surface.**

**How durable is Caesarstone? Tough, yes – Indestructable, No** Caesarstone is resistant to cracks, scratches and stains. However, like most materials, excessive force and/or pressure from objects can damage the surface. As with any surface, Caesarstone can be permanently damaged by exposure to strong chemicals and solvents. Use of a minimum 1/8" pencil round radius on an edge detail profile can reduce the susceptibility for chipping on the edge. A greater radius is recommended for high traffic areas.

Caesarstone surfaces are scratch resistant; however, avoid using sharp objects such as sharp knives or screwdrivers directly on the surface. The use of a cutting board is always recommended.

# Special Care Considerations Form



## Special Care Considerations for Honed/Textured/Concrete/Motivo™ Finishes

Caesarstone is proud to offer select colors in a **Honed, Textured, Concrete** and **Motivo™** finish.

Please note that **Honed, Textured, Concrete** and **Motivo™** finishes will require more daily maintenance than our polished finishes. Since there is more exposed surface area with these finishes, metal marks, finger prints, and other signs of daily living will be more apparent, especially on darker colors. However, superficial marks like these can be removed with a little effort by using non-abrasive cleaning products such as Soft Scrub® Gel with Bleach Cleanser. Rinse thoroughly with water and dry after using cleaner.

By signing this document, you agree that the properties of these unique finishes have been fully explained to you, and that you understand that more frequent cleaning may be required to keep the product looking new and free of marks. You also understand that while Caesarstone has a Residential Lifetime\* Warranty, this warranty covers failures caused by product defects when the material is installed by a Caesarstone Certified Fabricator. Temporary marks that are common on these finishes are not covered by our Caesarstone warranty.

For additional warranty information, please refer to the Residential Lifetime\* Warranty and Care and Maintenance sections of the Caesarstone USA website at [www.CaesarstoneUS.com](http://www.CaesarstoneUS.com).

NAME OF PURCHASER

NAME OF DEALER/FABRICATOR

SIGNATURE OF PURCHASER

DATE

SIGNATURE OF SALESPERSON

DATE

\* Some restrictions apply. Copies of our Lifetime Warranty are available at authorized dealers. Learn more by visiting [www.CaesarstoneUS.com](http://www.CaesarstoneUS.com) or calling 877.978.2789.

RESIDENTIAL LIFETIME  
&  
COMMERCIAL LIFETIME LIMITED  
WARRANTIES

### Exclusions from the warranties given to each purchaser of a countertop from the fabricator

#### **The following items or events will void the Residential Lifetime Warranty or the Commercial Lifetime Limited Warranty:**

- Any imperfection that is visible at the time of fabrication or installation and has not been cut around during fabrication.
- Any claims arising from not batch-matching the slabs in the installation.
- Any claims arising from not properly checking color between slabs, even if the batch numbers are the same.
- Changing the original surface finish of the slabs by repolishing, honing, sealing, or otherwise altering the factory finish.
- Any creative use of the slabs, such as bending or curving. Although this is possible, it is not a process that the Distributor has control over and therefore the Distributor cannot accept responsibility for it.
- Polishing the back of the slabs (except for laminations).
- Milling or reducing the thickness from the back of the slab.
- Securing mechanical fasteners directly onto the slabs.
- Removing the Caesarstone product information from the back of the slabs.
- Not following the recommended minimum edge profile details.
- Claims for scratches, chips or abrasion damage to the surface.
- Any mechanical damage caused by hitting or knocking the slabs.
- Any chemical damage.
- Not allowing 1/8" space from edge of product for expansion.
- Any failure due to inadequate support.
- Any failure due to improper fabrication and or installation.

## RESIDENTIAL LIFETIME WARRANTY

Caesarstone USA, Inc. will warrant from the original date of installation material that fails due to any manufacturing defect when fabricated and installed by a Caesarstone Certified Fabricator. This warranty applies to the repair or replacement of failed material that has been permanently installed in your residence. The option to repair or replace the material is at the sole discretion of Caesarstone USA, Inc.

This Residential Lifetime Warranty is available only to the original owner of a single family residence in which Caesarstone has been originally installed. In the case of a newly constructed single-family residence, this warranty is available to the "first" owner purchasing the residence with Caesarstone permanently installed and is transferable according to the terms and conditions stated below.

### Terms and Conditions

This warranty applies to a product that was installed after February 15, 2008.

- A. This warranty applies only to Caesarstone quartz surfacing materials and does not apply to any other products, including other quartz surfacing products manufactured or supplied by any other party, except Caesarstone USA, Inc.
- B. This warranty applies only to Caesarstone quartz surfacing materials that have been permanently installed in the interior of single-family residences and have not been moved from their original installation. If after or during installation you decide that you do not like the color or finish you selected, that decision is not covered under this warranty.
- C. This warranty does not cover any residence where the owner is not the occupant.
- D. This warranty does not cover materials and/or services that have not been paid in full.
- E. This warranty applies only to materials that have been maintained according to the Caesarstone Care & Maintenance guidelines. Care & Maintenance guidelines are available at [www.CaesarstoneUS.com](http://www.CaesarstoneUS.com)
- F. To request service under this warranty you must contact the company who sold you Caesarstone or contact Caesarstone USA, Inc. directly at (877) 978-2789 within thirty (30) days of the failure of Caesarstone quartz surfacing materials.
- G. Following installation, you must register your product within thirty (30) days in order to activate your warranty. Simply complete the online form made available at <http://warranty.Caesarstoneus.com>. In the event that no record of your warranty is on file, you must provide proof of purchase in the form of a copy of your original receipt or invoice showing the name of the Owner, Authorized Dealer and Caesarstone Certified Fabricator. Upon receipt of your

original receipt or invoice showing the name of the Owner, Authorized Dealer and Caesarstone Certified Fabricator, Caesarstone USA, Inc. will fully honor this warranty even though no warranty is on file. You must agree to cooperate with Caesarstone USA, Inc. or its authorized agents in the inspection of the product and assist us in efforts to perform our obligations under this warranty.

- H. This warranty is transferable under the following conditions:  
The original or first owner must have initially registered the warranty with Caesarstone USA, Inc. as specified in item F. The original or first owner must submit to Caesarstone USA, Inc. in writing the name, address and phone number of the new owner. The new owner will receive a prorated 10-year limited warranty, which is prorated from the original date of installation. In no event will the transferred warranty exceed ten (10) years from the date of the original installation.
- I. In the event that Caesarstone quartz surfacing materials fail due to a manufacturing defect, Caesarstone USA, Inc. will, at its sole discretion, repair or replace such materials. Caesarstone USA, Inc. will seek to obtain the best possible result, whether we decide to repair or replace your installation. However, exact color match is never guaranteed. All decisions regarding this warranty are at the sole discretion of Caesarstone USA, Inc. No representative, dealer, salesperson, distributor, fabricator or any other person is authorized to make any warranty or promises on behalf of Caesarstone USA, Inc. with respect to Caesarstone quartz surfacing products.

### Exclusions

1. This warranty does not cover use for any commercial purposes. Commercial use includes but is not limited to, use in a store, rental properties, office or any other place of business.
2. This warranty does not cover products installed in any outdoor application.
3. This warranty does not cover products used as flooring material.
4. This warranty does not cover improper use or abuse. Improper use or abuse includes, but is not limited to, damage from mishandling of the product, damage from excessive heat or uneven exposure to weather conditions, physical or chemical abuse and damage from improper care and maintenance.
5. This warranty does not cover chips or other excessive impact damage in the product.
6. This warranty does not cover scratches. Caesarstone is a very hard material and highly scratch resistance but not scratch proof. Proper care must be exercised including the use of a cutting board as part of your care and maintenance.
7. This warranty does not cover routine maintenance.

Routine maintenance includes but is not limited to, minor conditions such as removing stains and water spots by following the techniques specified in the Caesarstone online Care & Maintenance Guidelines at [www.CaesarstoneUS.com](http://www.CaesarstoneUS.com)

8. This warranty does not cover failures due to fabricators/installers not following the prescribed fabrication and installation procedures as outlined by Caesarstone USA, Inc. Improper fabrication and/or installation is the sole responsibility of the fabricator and/or installer.
9. This warranty does not cover any defects that were visible at the time of fabrication and were not avoided during fabrication. Fabricators are required to perform a visual inspection of all materials prior to fabrication and again prior to installation.
10. This warranty does not cover seam appearance or seam performance, adhesives, caulk or other accessory items. Once the product is installed, the two main reasons for seam separation or cracking are the shifting or movement of the substrate, cabinets or foundation, and thermal shock. Thermal shock can occur when a hot pan, dish or other receptacle or object is left on the countertop for more than a brief period. Trivets or hot pads should always be used. These issues are not considered material defects and are subject to proper care and maintenance by the owner.
11. This warranty does not cover any chemical damage.
12. This warranty does not cover any creative use of the material including bending or curving.
13. This warranty does not cover material that has been milled or reduced in thickness.
14. This warranty does not cover the installation of sinks.
15. This warranty does not cover securing mechanical fasteners directly into the material.
16. This warranty does not cover any failures due to inadequate support for the installation. This includes overhangs in excess of the recommendations provided by Caesarstone which are inadequately supported.
17. This warranty does not cover any chips or cracks that are a result of "dry" cutting or polishing.
18. This warranty does not cover chips or cracks that are a result of not following the minimum requirements for edge details.
19. This warranty does not cover mitered edges where the joint is not cut correctly.
20. This warranty does not cover the altering of any factory applied finish. Only colors listed as available in our brochure, sample book or on our website as "honed" are eligible under this warranty. Any issues arising from the practice of "in-shop" honing are the sole responsibility of the fabricator.
21. This warranty does not cover temporary marks that are common to honed finishes such as metal marks, fingerprints or other signs of daily living. A signed "Special Care Considerations for Caesarstone Honed Finishes" form is required to be submitted to Caesarstone or its assigns to receive coverage under this warranty. This form must be signed by the end user/owner of the finished installation.
22. This warranty does not cover additional modifications such as plumbing, electrical, tile, cabinets, flooring etc that may be necessary to repair or replace the Caesarstone product covered under this warranty.
23. This warranty does not cover natural variations in the color, size, shape and distribution of the pattern of the natural quartz or the natural variations in background tone. These characteristics are inherent and unique characteristics of the product. Color samples provided to consumers, dealers and fabricators are only representative and not an exact replication of what will be installed in your home.
24. This warranty does not cover what is referred to as spots or blemishes smaller than a U.S. ten (10) cent piece. A certain level of spots or blemishes are inherent in the manufacturing process and do not affect the structural integrity of the material.
25. Caesarstone materials contain important product information on the back of each slab. Removing this product information will void the warranty.

Caesarstone USA, Inc. is not responsible for damage or injury caused in whole or in part by acts of God, job site conditions, and architectural, engineering design, and structural movement, acts of vandalism or accidents.

Caesarstone USA, Inc. shall not be responsible in either contract or tort for any loss of direct, indirect, consequential, incidental, special, exemplary, or punitive damages arising out of the use or the inability to use the products covered by this warranty. Some states do not allow exclusion or limitation of incidental damages, so the above limitations or exclusions may not apply to you.

THE FOREGOING IS THE COMPLETE WARRANTY FOR CAESARSTONE AND SUPERSEDES ALL OTHER WARRANTIES AND REPRESENTATIONS, WHETHER ORAL OR WRITTEN. EXCEPT AS EXPRESSLY SET FORTH ABOVE, NO OTHER WARRANTIES ARE MADE WITH RESPECT TO CAESARSTONE AND CAESARSTONE USA, INC. EXPRESSLY DISCLAIMS ALL WARRANTIES NOT STATED HEREIN, INCLUDING, TO THE EXTENT PERMITTED BY APPLICABLE LAW, ANY WARRANTY THAT MAY EXIST UNDER NATIONAL, STATE, PROVINCIAL OR LOCAL LAW INCLUDING BUT NOT LIMITED TO ANY IMPLIED WARRANTY OF MERCHANTABILITY OR FITNESS FOR A PARTICULAR PURPOSE. SOME STATES OR OTHER JURISDICTIONS DO NOT ALLOW THE EXCLUSION OF IMPLIED WARRANTIES, SO THE ABOVE LIMITATIONS MAY NOT APPLY TO YOU.

This warranty gives you specific legal rights, and you may also have other rights which vary from State to State.





## COMMERCIAL LIFETIME WARRANTY (PRODUCT ONLY)

CAESARSTONE USA Inc. warrants to the owner of the original installation that Caesarstone quartz surfacing, when fabricated and installed by a Caesarstone Certified Fabricator/Installer, shall be free of manufacturing/material defects. This warranty applies to the repair or replacement of defective Caesarstone quartz slab that has been permanently installed and has remained in its original location. The option to repair or replace is at the sole discretion of Caesarstone USA Inc.

Caesarstone USA Inc. makes no express or implied warranty including without limitation, the warranties of merchantability, fitness for a particular purpose, or from any other course of dealing or trade usage regarding the product. No warranty whatsoever is made in regards to materials produced or provided by other manufacturers.

Caesarstone USA Inc. sole responsibility and liability under this warranty shall be to repair, or to replace, at Caesarstone's sole option, the products shown to be defective, during the warranty period. Caesarstone USA Inc. shall have no liability for any loss, expense or damage, as a result of the installation of Caesarstone material. Under no circumstances shall Caesarstone USA Inc. be liable for indirect, punitive, consequential, special or any other similar damages, including but not limited to, loss of profits, business interruption or any other loss.

The original owner must provide Caesarstone USA Inc. with prompt notice of any alleged defect by contacting Warranty Services at 877-9QUARTZ (877-978-2789). Caesarstone USA Inc. or its authorized agents must be permitted to inspect the product and to follow our warranty procedures. All decisions regarding the existence of manufacturing defects or affecting this warranty shall be made by Caesarstone USA Inc. and shall be final and binding on all parties. No representative, dealer, salesperson, distributor, fabricator or any other person is authorized to make any warranty or promises on behalf of Caesarstone USA Inc. with respect to Caesarstone quartz surfacing products.

In the event of defect covered under this warranty, Caesarstone shall have the sole discretion whether to repair or replace Caesarstone quartz material (not including the cost of installation and/or fabrication). Without derogating from the aforementioned, replacement of defective Caesarstone quartz slab will be subject to inventory constraints. In addition, the replaced slab may not be exactly the same as the defective slab.

### TERMS & CONDITIONS:

#### **This lifetime limited warranty applies only to product installed after November 1, 2014.**

1. This warranty applies only to Caesarstone quartz surfacing materials. This warranty does not apply to any other products, including other quartz surfacing products manufactured or supplied by any other party, except Caesarstone USA Inc.
2. This warranty applies only to Caesarstone materials that are permanently installed in commercial structures and that have not been moved from their original installation.
3. This warranty does not apply to unoccupied structures.
4. This warranty does not cover materials and/or services that have not been paid in full.
5. This warranty only applies to materials that have been maintained according to Caesarstone Warranty and Care & Maintenance guidelines. Care & Maintenance guidelines are available at [www.caesarstoneus.com](http://www.caesarstoneus.com)
6. Following installation, you must register your product within thirty (30) days in order to activate your warranty. Complete the online warranty registration form at <http://www.caesarstoneus.com-service/warranty/registration/>. In the event that no record of your warranty is on file, you must provide proof of purchase in the form of your original receipt or invoice showing the name of the Owner and Certified Caesarstone Fabricator. Upon receipt of this original documentation Caesarstone USA Inc. will fully honor this warranty. You must agree to cooperate with Caesarstone USA Inc. or its authorized agents in the inspection of the product and assist us in efforts to perform our obligations under this warranty. 7. To request service under this warranty you must contact the company who sold you Caesarstone or contact Caesarstone USA Inc. Warranty Services directly at 877-9QUARTZ (877-978-2789) promptly (within 30 days).
8. Laws and building safety regulations governing the design, engineering and construction of installations vary widely. Caesarstone USA Inc. assumes no responsibility or obligations with respect to the selection of product for the installation or the design, engineering and construction of the installation.
9. Commercial Property shall consist of any location open to the general public for business use, private properties subject to residential or commercial rental or lease, or properties designated as hotels, motels or other temporary residence applications.
10. This commercial warranty is not transferable. This warranty is issued to the original owner of the structure in which Caesarstone was installed and expires upon transfer of the ownership of the structure to a third party.



## EXCLUSIONS:

1. Routine maintenance and minor conditions such as surface stains and water spots that may be corrected by following the techniques specified in the Caesarstone USA Inc. Care & Maintenance guide are not covered.
2. This warranty does not cover Caesarstone products used in outdoor applications.
3. This warranty does not cover Caesarstone products used in flooring applications.
4. This warranty does not cover improper use or abuse. Improper use or abuse includes, but is not limited to, damage from mishandling the product, damage from excessive heat or uneven exposure to weather conditions, physical or chemical abuse and damage from improper care and maintenance.
5. This warranty does not cover failures due to fabricators failing to follow the prescribed fabrication and installation procedures as outlined by Caesarstone USA Inc. Improper fabrication and/or installation is the sole responsibility of the fabricator/installer.
6. This warranty does not cover chips or other excessive impact damage to the product.
7. This warranty does not cover surface scratches. Caesarstone is an extremely durable material and is scratch resistant but not scratch proof. Reasonable care should be taken including the use of a cutting board.
8. This warranty does not cover products installed with a known or visible manufacturing defect at the time of installation, including, but not limited to, color variance particularly at seam locations.
9. This warranty does not cover seam performance or seam appearance, adhesives, caulks or any other accessory items. Once the product is installed the two main reasons for seam separation or cracking are the shifting or movement of the substrate, cabinets, foundation or thermal shock.
10. This warranty does not cover any creative use of the product including bending or curving.
11. This warranty does not cover product that has been milled or otherwise reduced in thickness.
12. This warranty does not cover the installation of sinks, other plumbing fixtures or appliances.
13. This warranty does not cover altering of the factory applied finish.
14. This warranty does not apply to products with "honed" finishes. Honed finishes require more daily maintenance and may not be appropriate for high traffic areas.
15. This warranty does not cover mitered edges where the joint is not cut correctly.
16. This warranty does not cover natural variations in color, size, shape or distribution of the pattern of the natural quartz or the natural variations in background tone. These characteristics are inherent and unique characteristics of the product. Color samples provided to architects, designers, dealers, consumers and fabricators are only representative and not an exact replication of what will be installed.
17. This warranty does not cover what is referred to as spots or "beauty marks" smaller than a ten-cent (10) piece. A certain level of spots or 'beauty marks' are inherent in the manufacturing process and do not affect the structural integrity of the product.
18. Caesarstone shall not be liable for any additional work such as plumbing, electrical, tile, cabinets, flooring, etc. that may need to be done as a result for a repair or replacement of a defective Caesarstone slab covered under this warranty.
19. This warranty does not cover damages caused by work such as plumbing, electrical, tile, cabinets, flooring, etc.
20. This warranty does not cover product that has been moved from its original installation location.
21. Caesarstone materials contain important information on the back of each slab. Removing of this product information shall void the warranty. Caesarstone USA Inc. is not responsible for damage or injury caused in whole or in part by acts of God, job site conditions, architectural/engineering design, structural movement, accidents or acts of vandalism.

Caesarstone USA Inc. shall not be responsible either in contract or tort for any loss of direct, indirect, consequential, incidental, special, exemplary or punitive damages arising out of the use or the inability to use the products covered by this warranty. Some states do not allow exclusion or limitation of incidental damages, so the above limitations or exclusions may not apply to you.

THE FOREGOING IS THE COMPLETE WARRANTY FOR CAESARSTONE PRODUCTS AND SUPERCEDES ALL OTHER WARRANTIES AND REPRESENTATIONS, WHETHER ORAL OR WRITTEN EXCEPT AS EXPRESSLY SET FORTH ABOVE. NO OTHER WARRANTIES ARE MADE WITH RESPECT TO CAESARSTONE AND CAESARSTONE USA INC. EXPRESSLY DISCLAIMS ALL WARRANTIES NOT STATED HEREIN, INCLUDING , TO THE EXTENT PERMITTED BY APPLICABLE LAW ANY WARRANTY THAT MAY EXIST UNDER NATIONAL, STATE , PROVINCIAL OR LOCAL LAW INCLUDING BUT NOT LIMITED TO ANY IMPLIED WARRANTY OF MERCHANTABILITY OR FITNESS FOR A PARTICULAR PURPOSE. SOME STATES OR OTHER JURISDICTIONS DO NOT ALLOW THE EXCLUSION OF IMPLIED WARRANTIES, SO THE ABOVE LIMITATIONS MAY NOT APPLY TO YOU. THIS WARRANTY GIVES YOU SPECIFIC LEGAL RIGHTS AND YOU MAY HAVE OTHER RIGHTS WHICH VARY FROM STATE TO STATE.

# Caesarstone MSDS

Product Name: Caesarstone®/Concetto®

MSDS Date: March 26th, 2012

## 1. PRODUCT AND COMPANY IDENTIFICATION

Product Name: Caesarstone®/Concetto®

Product Use: Caesarstone® Quartz Surfacing and Concetto® Natural Stone Surfacing

Company: Caesarstone, Kibbutz Sdot-Yam, MP Menashe, 38805 Israel

Emergency

Phone Number: 972-4-6364-555

## 2. COMPOSITION/INFORMATION ON INGREDIENTS

Material	CAS Number	%
Crystalline Silica and other natural stone	14808-60-7	>85
Cristobalite	14464-46-1	<50
Polymeric resin		7-15
Additives		0-8

## 3. HAZARDS IDENTIFICATION

### Emergency Overview

**Information Pertaining to Particular Dangers for Man and Environment: Classification:** This preparation is not classified as hazardous according to the latest adaptation of European Union Directives 67/548/EEC and 1995/45/EC.

### Potential Health Effects

Quartz surfaces products are not hazardous as shipped. However, operations such as sawing, grinding, routing, drilling and sanding can generate dust. Inhalation of such dusts, smoke and vapors may cause upper respiratory tract irritation. Symptoms may include burning sensation, coughing, sneezing, and sore throat. Skin contact with dust may produce transitory mechanical irritation. Symptoms may include redness and itching. High concentrations of dusts may cause irritation to the eyes causing burning, redness, and tearing. This product is not expected to be toxic if ingested.

Overexposure to airborne crystalline silica can cause silicosis, a chronic and progressively debilitating disease, characterized by the formation of silica-containing scar tissue in the lungs. Symptoms of silicosis include coughing, difficulty breathing, wheezing and progressive impairment of lung function. In addition to silicosis, epidemiology studies show limited evidence of an excess of lung cancer in occupations involving exposures to crystalline silica, such as stone cutters and granite industry workers.

Individuals with chronic respiratory disorders may be adversely affected by any fume or airborne particulate matter exposure. Persons with preexisting skin disorders may be more susceptible to the effects of this material.

## Carcinogenicity Information

The following components are listed by IARC, NTP, OSHA or ACGIH as carcinogens.

Material	IARC	NTP	OSHA	ACGIH
Silica, Crystalline (quartz and cristobalite)	1	x	yes	A2

## 4. FIRST AID MEASURES

**Eye Contact:** Flush immediately with copious amounts of water for a minimum of 15 minutes. Seek immediate medical attention.

**Skin Contact:** Wash affected area with soap and plenty of water. Seek medical attention if adverse effect occurs.

**Inhalation:** Remove person to fresh air. If breathing is difficult, or has stopped, administer artificial respiration (mouth-to-mouth) or oxygen as indicated. Call a physician.

**Ingestion:** Product in its marketed form is inert. If large amounts are swallowed, seek medical attention or advice.

## 5. FIRE FIGHTING MEASURES

**Auto Ignition:** Quartz surfaces products can be combusted only with difficulty.

**Fire Spreading Rating:** 5

**Smoke Developed Rating:** 25

**Flash Point:** 490°C

**Flammable Limits in Air (% by Volume):** NA

**Extinguishing Media:** Water, Dry Chemical, CO<sub>2</sub> and Foam.

**Special Fire Fighting Procedures:** Keep personnel away and upwind of fire. Use self-contained breathing apparatus with full face mask.

**Unusual Fire and Explosion Hazards:** Decomposition products resulting from the polymer and pigments degrading at elevated temperatures include various hydrocarbons, carbon dioxide, carbon monoxide and water. Fumes of metal oxides and mica particles could also be released.

## 6. ACCIDENTAL RELEASE MEASURES

**Cleanup and Disposal of Spill:** Solid slabs can simply be gathered and disposed of as necessary. If large amounts of dust or wastes are created by cutting process, vacuum or sweep up material avoiding dust generation or dampen spilled material with water to avoid airborne dust. Wear suitable respiratory protection and protective clothing where necessary. If large quantities of this material enter the waterways contact the Environmental Protection Authority, or local Waste Management Authority. Dispose of waste in accordance with local, state and federal regulations.

## 7. HANDLING AND STORAGE

**Handling/Storage:** Avoid breathing dust. Wash hands before eating, drinking, smoking, or using toilet facilities. Wash thoroughly after work using soap and water. Good industrial hygiene practices should be followed when handling this material. Product is heavy and breakable; handle with care to avoid injury and prevent damage.

## 8. EXPOSURE CONTROLS/PERSONAL PROTECTION

### Exposure Guidelines:

Reference	Substance	Guideline or limit (mg/m <sup>3</sup> )
OSHA (29 CFR 1910.1000- Table Z-3) OSHA Vacated PELs	Respirable crystalline silica: quartz, cristobalite, and triymite	Total dust, (30 mg/m <sup>3</sup> / % SiO <sub>2</sub> + 2); Respirable dust, (10 mg/m <sup>3</sup> / % SiO <sub>2</sub> + 2) as 8hr TWAs 0.1 mg/m <sup>3</sup> TWA (respirable dust)
ACGIH (2010)	Respirable crystalline silica: quartz, cristobalite, and triymite	0.025 mg/m <sup>3</sup> (8hr TWA)
NIOSH	Respirable crystalline silica: quartz, cristobalite, and triymite	0.05 mg/m <sup>3</sup> (8hr TWA)

### Abbreviations:

TWA = time-weighted average, ACGIH = American Conference of Governmental Industrial Hygienists, Inc. OSHA = Occupational Safety and Health Administration, NIOSH = National Institute of Occupational Safety and Health.

**Engineered Controls:** Ventilation must be adequate to maintain the ambient workplace atmosphere below the exposure limit(s) outlined in the MSDS. General room ventilation is satisfactory under anticipated use conditions. Generally, machinery and tools involving the use of water are required.

### PERSONAL PROTECTIVE EQUIPMENT

**Eye/Face Protection:** If eye contact while using this product may be anticipated, wear appropriate safety glasses with side shields or chemical goggles as described by OSHA's eye and face protection regulations in 29CFR 1910.133 or European Standard EN166.

**Respiratory Protection:** Respiratory equipment approved by NIOSH/MSHA for protection against organic vapors and dusts is necessary to avoid inhalation of excessive air contaminants. The appropriate respirator selection depends on the type and magnitude of exposure (refer to 29 CFR 1910.134 for appropriate NIOSH approved respirators and to the NIOSH Pocket Guide to Chemical Hazards, DHHS (NIOSH) Publication NO. 2001-145 for equipment selection). Use a positive pressure air supplied respirator if there is a potential for an uncontrolled release, exposure levels are not known or under any other circumstances where air purifying respirators may not provide adequate protection.

**Skin Protection:** During cutting, grinding or sanding operations use body protection appropriate for task including work gloves if handling sharp or rough edges and steel-toed shoes if lifting product.

### PREVENTION

- P260 Do not breathe dust generated in the cutting, grinding and polishing processes.
- P264 Wash face and hands thoroughly after handling.
- P270 Do not eat, drink or smoke when using this product.
- P284 Wear respiratory protection for particles (P3).

### FIRST AID MEASURES

- P314 Get medical advice/attention if you feel unwell.
- P501 Dispose of remains in accordance with local regulation.
- R20 Harmful by inhalation.
- R48 Danger of serious damage to health by prolonged exposure.

## HYGIENE

S22 Do not breathe the dust.

S38 Use personal protective equipment P3.

Classification according to directive 1999/45/EC

## 9. PHYSICAL AND CHEMICAL PROPERTIES

**Physical Appearance:** Multi-colored engineered stone

**Odor:** Odorless

**pH:** NA

**Specific Gravity:** 2.4

**Water Solubility:** Insoluble

**Flash Point:** 490°C

**Melting Point:** NA

**Boiling Point:** NA

**Vapor Pressure:** NA

**% Volatiles:** NA

**Viscosity:** NA

## 10. STABILITY AND REACTIVITY

**Chemical Stability:** Stable at normal temperatures and storage conditions.

**Incompatibility with Other Materials:** This product is incompatible with hydrofluoric acid.

**Hazardous Decomposition Products:** Thermal decomposition can release various hydrocarbons, carbon dioxide, carbon monoxide and water. Fumes of metal oxides and mica particles could also be released.

**Hazardous Polymerization:** Will not occur

## 11. TOXICOLOGICAL INFORMATION

### Acute Effects

*Crystalline Silica*

Inhalation (human) LCLo: 0.3 mg/m<sup>3</sup>/10Y

Inhalation (human) TCLo: 16 mppcf/8H/17,9Y

Intermittent; focal fibrosis, (pneumoconiosis), cough, dyspnea.

Inhalation (rat) TCLo: 50 mg/m<sup>3</sup>/6H/71W

Intermittent; liver – tumors

Oral LD<sub>50</sub> RAT: 500 mg/kg

### Chronic Effects

*Crystalline Silica*

**Silicosis:** caused by the inhalation and retention of respirable crystalline silica dust.

**Carcinogenicity:** The International Agency for Research on Cancer (IARC) concluded that "crystalline silica inhaled in the form of quartz or cristobalite from occupational sources is *carcinogenic to humans* (Group 1)." The National Toxicology Program (NTP), in its *Ninth Annual Report on Carcinogens*, concluded that silica, crystalline (respirable) is "known to be a carcinogen, based on sufficient evidence in experimental animals and in humans." The U.S. Occupational Safety and Health Administration (OSHA) does regulate crystalline silica (quartz) as a carcinogen. The American Conference of Governmental Industrial Hygienist (ACGIH), noted in the "TLV & BEIs" book, version of 2011, that silica, crystalline (respirable) and cristobalite is A2 (Suspected Human Carcinogen - human data are accepted as adequate in quality but are conflicting or insufficient to classify the agent as a confirmed human carcinogen).

The American Thoracic Society position on the issue of silica carcinogenicity was published in *Adverse Effects of Crystalline Silica Exposure*, American Journal of Respiratory and Critical Care Medicine, Vol. 155, pp. 761-765 (1997). The official statement concluded that “The available data support the conclusion that silicosis produces increased risk for bronchogenic carcinoma. The cancer risk may also be increased by smoking and other carcinogens in the workplace.”

**Aggravation of Pre-existing Conditions:** Inhalation may increase the progression of tuberculosis; susceptibility is apparently not increased. Persons with impaired respiratory function may be more susceptible to the effects of this substance. Smoking can increase the risk of lung injury.

**Mutagenicity:** No Data

**Reproductive Effects:** No Data

**Developmental Effects:** No Data

## 12. ECOLOGICAL INFORMATION

Toxicity is expected to be low based on insolubility in water.

**Environmental Fate:** ND

**Environmental Toxicity:** ND

**ISO 14001 Certification:** Caesarstone is ISO 14001 certified for Environmental Management Systems.

**GREENGUARD Certification:** Caesarstone is compliant with GREENGUARD standard.

*Quartz (14808-60-7)*

**Environmental Fate:** No information found

**Environmental Toxicity:** No information found

## 13. DISPOSAL CONSIDERATIONS

**Waste Disposal Method:** Preferred options for disposal are (1) recycling, (2) incineration with energy recovery, and (3) landfill.

Whatever cannot be saved for recovery or recycling should be managed in an appropriate and approved waste disposal facility.

Processing, use or contamination of this product may change the waste management options.

State and local disposal regulations may differ from federal disposal regulations. Dispose of in accordance with federal, state and local requirements.

## 14. TRANSPORTATION INFORMATION

ADR/RID/IMO/ICAO/US DOT	Proper Shipping Name	Not Regulated
	Hazard Class	Not Regulated
	ID Number	Not Regulated
	Packaging Group	Not Regulated

## 15. REGULATORY INFORMATION

### U.S. Federal Regulations:

#### SARA Title III Hazard Classes:

Fire Hazard: No  
Reactive Hazard: No  
Release of Pressure: No  
Acute Health Hazard: No  
Chronic Health Hazard: Yes

**TSCA:** All components of this product are on the TSCA inventory or are exempt from TSCA Inventory requirements

**U.S. State Regulations:** California Prop 65 List: Crystalline silica is classified as a substance known to the state of California to be a carcinogen.

## 16. OTHER INFORMATION

### National Fire Protection Association NFPA(R) and Hazardous Materials Identification System (HMIS)

#### Hazard Ratings:

Health Hazard: 1  
Flammability: 0  
Reactivity: 0

#### Key Legend Information:

NA – Not Applicable  
ND – Not Determined  
ACGIH – American Conference of Governmental Industrial Hygienists  
OSHA – Occupational Safety and Health Administration  
IARC – International Agency for Research on Cancer  
IDLH – Immediately Dangerous to Life and Health

The information contained herein is based on the data available to us and is believed to be correct. However, Caesarstone makes no warranties, expressed or implied, regarding the accuracy of these data or the results to be obtained from the use thereof.

Check with Caesarstone before using or supplying this product for other applications, different to those previously stated.

In addition, the contents of this Safety Data Sheet must not be interpreted as a recommendation to use any product in violation of the laws, safety practices or patents in force on any material or its use. It is the responsibility of the recipient of our product to check the corresponding rules and regulations. Under no circumstances does the data contained in this Safety Data Sheet constitute a guarantee of specific properties or create any contractual relationship.

This Safety Data Sheet (MSDS) is according to the CLP Regulation, (EC) No 1272/2008. For further information follow the instructions in the *Respirable Crystalline Silica – Health Hazards & Protection Guide* published by the manufacturer. Further information is available at [www.nepsi.eu](http://www.nepsi.eu) and in the *Guide to Good Practice for the Agreement on Workers' Health Protection Through the Good Handling and Use of Crystalline Silica and Products Containing It*.

### Other Regulations:

#### EU Marking and Labeling

Symbol: None  
Risk Phrases: None  
Safety Phrases: None

**Inventory Information:** The substances in this preparation have been checked against the European Inventory of Existing Commercial Substances (EINECS), the European List of Notified Chemical Substances (ELINCS), and the No Longer Polymer (NLP) list. Substances not identified on these inventories are exempt.

PEL – Permissible Exposure Limit  
TWA – Time Weighted Average  
STEL – Short Term Exposure Limit  
NTP – National Toxicology Program  
TLV – Threshold Limit Value





**Please complete and return this page to:**

Caesarstone USA, Inc.  
Corporate Office  
9275 Corbin Avenue  
Northridge, CA 91324 USA

## Receipt Form

The undersigned acknowledges receipt of the Caesarstone® *Fabrication & Health Protection Guide*, including the Caesarstone MSDS, and the accompanying instructional movie.

### **Fabricator's Business Details:**

*Company Name:* \_\_\_\_\_

*Address:* \_\_\_\_\_

*City:* \_\_\_\_\_

*State:* \_\_\_\_\_

*Zip Code:* \_\_\_\_\_

*Country:* \_\_\_\_\_

*Telephone Number:* \_\_\_\_\_

*Name:* \_\_\_\_\_

*Signature:* \_\_\_\_\_

*Date:* \_\_\_\_\_

Please note that the *Fabrication & Health Protection Guide* includes important health and safety information and instructions (including health hazards associated with crystalline silica dust, and recommended protection measures), as well as Caesarstone's MSDS dated March 26, 2012, and an instructional movie. Please review them carefully. **You should carefully adhere to all applicable local laws and regulations related to health and safety. We also recommend that you consult with your local occupational health professional and other advisors on the applicable laws, regulations and recommended protection measures.**







Corporate Office  
9275 Corbin Avenue  
Northridge, CA 91324 USA

T 877 9QUARTZ  
F 818 779 0099

[info@Caesarstoneus.com](mailto:info@Caesarstoneus.com)

[www.CaesarstoneUS.com](http://www.CaesarstoneUS.com)

Photography shot on location at: 1) Thea Segal Designs, Inc. – Residential project in Los Angeles, CA; 2) Built, Inc. – Silverlake “Six House” residential project, Los Angeles, CA.

© Copyright Caesarstone 2016.  
Caesarstone® is a registered trademark.

caesarstone®